



Review article

Life cycle assessment and its application to process selection, design and optimisation

Adisa Azapagic*

Department of Chemical and Process Engineering, University of Surrey, Guildford, Surrey GU2 5XH, UK

Accepted 1 March 1999

Abstract

As the pressures on the chemical and process industries to improve their environmental performance are increasing, the need to move away from narrow system definitions and concepts in environmental system management is becoming more apparent. Life Cycle Assessment (LCA) is gaining wider acceptance as a method that enables quantification of environmental interventions and evaluation of the improvement options throughout the life cycle of a process, product or activity. Historically, LCA has mainly been applied to products; however, recent literature suggests that it can assist in identifying more sustainable options in process selection, design and optimisation. This paper reviews some of these newly emerging applications of LCA. A number of case studies indicate that process selection must be based on considerations of the environment as a whole, including indirect releases, consumption of raw materials and waste disposal. This approach goes beyond the present practice of choosing Best Practicable Environmental Option (BPEO), by which it is possible to reduce the environmental impacts directly from the plant, but to increase them elsewhere in the life cycle. These issues are discussed and demonstrated by the examples of end-of-pipe abatement techniques for SO₂, NO_x and VOCs and processes for the production of liquid CO₂ and O₂. The integration of LCA into the early stages of process design and optimisation is also reviewed and discussed. The approach is outlined and illustrated with real case studies related to the mineral and chemical industries. It is shown that a newly emerging Life Cycle Process Design (LCPD) tool offers a potential for technological innovation in process concept and structure through the selection of best material and process alternatives over the whole life cycle. The literature also suggests that LCA coupled with multi-objective optimisation (MO) provides a robust framework for process design by simultaneously optimising on environmental, technical, economic and other criteria. Pareto-optimum solutions obtained in MO provide a number of options for improved design and operation throughout the whole life cycle. This approach therefore provides a potentially powerful decision making tool which may help to identify more sustainable solutions in the process industries. © 1999 Elsevier Science S.A. All rights reserved.

Keywords: Life cycle assessment; BPEO; BATNEEC; Waste minimisation; Multi-objective optimisation; Process design; System analysis

1. Introduction

The development of industrial technology has enabled the transformation of the environment in different ways, changing the nature and extent of the environmental impacts of industrial activities. Resource depletion, air, water and land pollution, are examples of the environmental problems which have emerged as a result of intensified interventions into the environment. One of the main problems associated with these activities is that they may not have an immediate effect and some may have a more global impact on the environment. This is becoming apparent with the increasing scientific awareness of the cumulative and synergistic

effects of some of the environmental impacts over space and time. For instance, emissions of greenhouse gases can occur locally, but the resulting greenhouse effect will have a global character.

It is therefore not surprising that pressures on those responsible for the environmental interventions to improve their performance are rising. Among these, the chemical and process industries find themselves constantly under the scrutiny of various pressure groups demanding more environmentally acceptable processes, products and practices through the ideas of 'waste minimisation', 'zero emission', 'producer responsibility', etc. One of the potential dangers of this is that the companies exposed to environmental pressures may simply respond to satisfy a particular group. However, this short-term approach may lead to costly long-term mistakes with little environmental improvement and no

*Tel.: +44-1483-259-170; fax: +44-1483-259-510; e-mail: a.azapagic@surrey.ac.uk

net business benefit. To avoid this, environmental issues must be assessed in a holistic way, alongside financial, technical and other criteria.

Life Cycle Assessment (LCA) is an environmental management tool that enables quantification of environmental burdens and their potential impacts over the whole life cycle of a product, process or activity. Although it has been used in some industrial sectors for about 20 years, LCA has received wider attention and methodological development only since the beginning of the 1990s when its relevance as an environmental management aid in both corporate and public decision making became more evident. Examples of this include incorporation of LCA within the ISO 14000 Environmental Management Systems (EMS) [1], EU Eco-Management and Audit Schemes (EMAS) [2]¹, and EC Directive on Integrated Pollution Prevention and Control (IPPC) [3,4] which require companies to have a full knowledge of the environmental consequences of their actions, both on- and off-site.

Integration of life cycle thinking into environmental system management started to change the way environmental problems were seen and tackled. It pointed out that, if sustainable solutions to environmental problems are to be found, then they must be sought on a more global level. Today, LCA is being used widely as a decision making tool; however, the methodology is still developing and a number of issues remain to be resolved. This paper reviews the state-of-the-art of methodological development and uses of LCA. In particular, it focuses on the application of LCA in process selection, design and optimisation as a tool for identifying clean technologies [5–8]. The procedures for incorporating into the system optimisation framework the environmental criteria alongside the economic and technical criteria are reviewed and discussed. It is shown that this approach can provide a potentially powerful decision making tool for managers, process engineers and designers.

2. Life cycle assessment

Life Cycle Assessment is a technique for assessing the environmental performance of a product, process or activity from ‘cradle to grave’, i.e. from extraction of raw materials to final disposal. Today’s LCA originates from ‘net energy analysis’ studies, which were first published in the 1970s [9–11] and considered only energy consumption over a life cycle of a product or a process. Some later studies included wastes and emissions [12–16], but none of them went further than just quantifying materials and energy use. At this point it was clear that a more sophisticated approach to complex environmental issues was needed.

As a result, in 1990, the Society for Environmental Toxicology and Chemistry (SETAC) initiated activities to

¹Although LCA is not mentioned explicitly in EMAS, its use is implied in Annex 1, section C (see [2]).

define LCA and develop a general methodology for conducting the LCA studies. Soon afterwards, the International Organisation for Standardisation (ISO) started similar work on developing principles and guidelines on the LCA methodology [17]. Although SETAC and ISO worked independently of each other, a general consensus on the methodological framework between the two bodies has started to emerge, with the difference being in the matter of detail only. While the ISO methodology is still being shaped, the methodology developed by SETAC remains widely accepted among LCA practitioners. The latter is briefly described in the following section with reference to the ISO methodology where appropriate.

2.1. Methodological framework for Life Cycle Assessment

Life Cycle Assessment, as defined by SETAC, is “a process to evaluate the environmental burdens associated with a product, process, or activity by identifying and quantifying energy and materials used and wastes released to the environment; to assess the impact of those energy and material uses and releases to the environment; and to identify and evaluate opportunities to effect environmental improvements” [18,19]. It follows the life cycle of a product, process or activity from extraction of raw materials to final disposal, including manufacturing, transport, use, re-use, maintenance and recycling (Fig. 1). Its main advantage over other, site-specific, methods for environmental

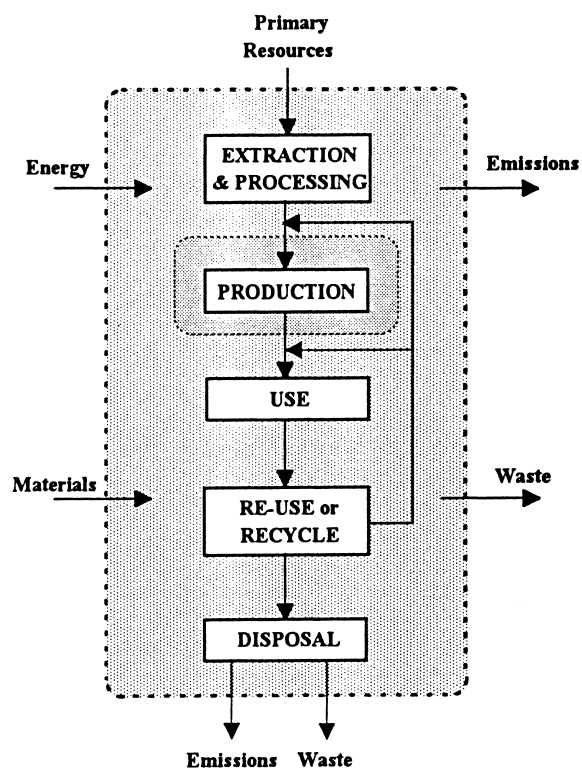

Fig. 1. Stages in the life cycle of a product (from Azapagic [20]).

analysis, such as Environmental Impact Assessment (EIA) or Environmental Audit (EA), lies in broadening the system boundaries to include all burdens and impacts in the life cycle of a product or a process, and not focusing on the emissions and wastes generated by the plant or manufacturing site only.

The methodological framework for conducting LCA, as defined by both SETAC [18] and ISO [17], comprises four main phases. The two approaches are compared below:

SETAC [18]	ISO-14040 [17]
1. Goal Definition and Scoping	Goal and Scope Definition (ISO14041) [21]
2. Inventory Analysis	Inventory Analysis (ISO14041) [21]
3. Impact Assessment	Impact Assessment (ISO14042) [22]
4. Improvement Assessment	Interpretation (ISO 14043) [23]

As indicated, the methodological framework proposed by ISO is similar to that defined by SETAC; the only substantial difference is noted in the final phase, as discussed below. The interactions among the LCA phases are shown in Fig. 2.

LCA is based on the kind of thermodynamic and system analyses which are central to process engineering [24]. Therefore, the first step in any analysis must be definition of the system under study. In LCA, this is done in the Goal Definition and Scoping phase [18]. The environment is then interpreted in the thermodynamic sense as ‘that which surrounds the system’, i.e. the whole universe except the system under study. Thus for these purposes, ‘the environment’ is defined along with the system, by exclusion. On this basis, Fig. 3 shows schematically the general problem of environmental system analysis. The system of interest exists because it produces goods and services, which are treated together as outputs. To generate these outputs, inputs of

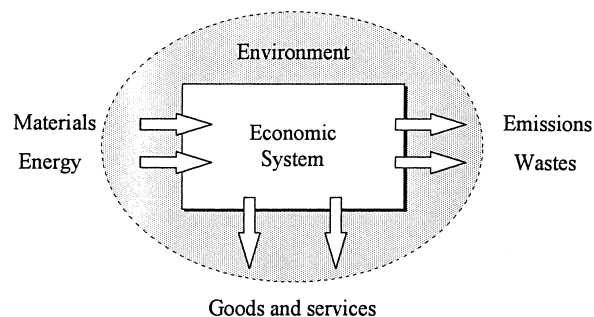

Fig. 3. Environmental system analysis (adapted from Azapagic and Clift [24]).

energy and materials are required. In a site-specific environmental analysis, such as EIA or EA, the system is the plant or manufacturing site and the inputs are related to the inputs of material and energy to that plant. In the LCA context, system boundaries are drawn from ‘cradle to grave’ to include all burdens and impacts in the life cycle of a product or a process, so that the inputs into the system become primary resources.

The system function is also specified within Goal Definition and Scoping and it is expressed in terms of the functional unit(s) as a measure of the function(s) that the system delivers. For instance, the function of packaging is to store a certain amount of liquid. If different packaging is to be compared, then the comparison should be based on an equivalent function. Therefore, the functional unit in this case can be defined as the amount of packaging needed to contain a certain amount of liquid under specified conditions and for a specified period of time.

In setting the system boundaries, it is useful to distinguish between ‘foreground’ and ‘background’ systems (or, strictly, sub-systems). The foreground system is defined as the set of processes directly affected by the study delivering a functional unit specified in Goal and Scope Definition [25]. The background system is that which supplies energy and materials to the foreground system, usually via a homogeneous market so that individual plants and operations cannot be identified. Differentiation between foreground and background systems is also important for deciding on the type of data to be used. The foreground system should be described by specific process data, while the background is normally represented by data for a mix or a set of mixes of different technologies or processes [25,26].

In the second, Inventory Analysis phase, material and energy balances are performed and the environmental burdens are quantified. The burdens are defined by resource consumption and emissions to air, water and solid waste. Aggregation of the burdens into a smaller number of impact categories (Classification) and evaluation of their potential impacts (Characterisation) is part of the third, Impact Assessment, phase (see Fig. 2). A number of methods have been suggested for the identification and quantification of environmental impacts [27–35]; however, the problem-

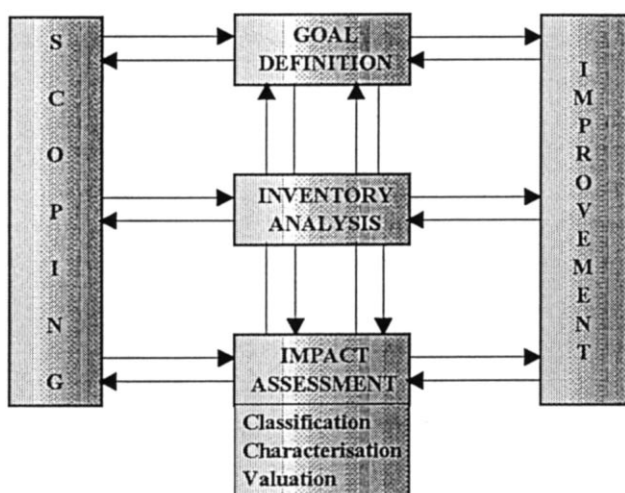

Fig. 2. Interactions between LCA stages (from Fava et al. [18]).

oriented method, developed by Heijungs et al. [36], is the most widely used. In this approach, the burdens are aggregated according to the relative contributions to specific potential environmental effects, such as global warming potential, acidification, ozone depletion etc. For instance, CO₂ is a reference gas for determining the global warming potential of other related gases, such as CH₄ and other VOCs.

Within the Impact Assessment phase, the impacts can be aggregated further into a single environmental impact function by attaching weights to the impacts to indicate their relative importance. This step, known as Valuation [18] or Value-choices [22], has proven to be the most controversial part of LCA because it implies subjective value judgments in deciding on the importance of different impacts. Valuation is typically not based on natural science [22] but on expressing preferences either by decision makers, ‘experts’ or by the public [37–42]. At present, there is no consensus on how to aggregate the environmental impacts into a single environmental impact function [22,37] nor even on whether such aggregation is conceptually and philosophically valid.

The final phase in the SETAC methodology is Improvement Assessment and is aimed at identifying the possibilities for improving the performance of the system. In the ISO methodology, this phase is known as Interpretation and, in addition to improvements and innovations, it covers identification of major stages in the life cycle contributing to the impacts, sensitivity analysis and final recommendations [43]. In the SETAC methodology, these additional steps are included within Goal Definition and Scoping and Inventory Analysis.

While the methodology is being developed, the use of LCA continues to increase. Some examples of LCA studies include assessment of the environmental impacts of consumer products; others are aimed at improvements of environmental performance or development of a new product or a process. Prior to focusing on the application of LCA for process selection and design in Section 4, different uses of LCA are reviewed and discussed next.

3. Applications of LCA

LCA is generally accepted as an application of system analysis whose prime objective is to provide a picture of the interactions of an activity with the environment, thus serving as a tool for environmental management. As such, LCA has two main objectives. The first is to quantify and evaluate the environmental performance of a product or a process and so help decision makers choose among alternatives. Another objective of LCA is to provide a basis for assessing potential improvements in the environmental performance of the system. The latter can be of particular importance to engineers and environmental managers, because it can suggest ways to modify or design a system in order to decrease its overall environmental impacts.

LCA has been used for both corporate and public decision making. Some of the more recent examples of LCA applications in corporate decision making include energy [44–48] and transport [49,50] sectors, chemical [51–55], nuclear [56,57], metal [58–61], polymer [62], paper and forest [63,64], textile and leather [65,66], water [67,68], electronic [69,70] and other industries. These applications have mainly included the following uses, but are not limited to:

- strategic planning or environmental strategy development,
- product and process optimisation, design, and innovation,
- identification of environmental improvements opportunities,
- environmental reporting and marketing,
- creating a framework for environmental audits.

Some of the uses of LCA, as identified by product manufacturers, are shown in Fig. 4. These results are based on an international survey of a number of organisations actively involved in LCA [71]. The data indicate that the most common reasons for performing an LCA are to improve environmental performance through analysis of products and to inform short and long-term policy decisions through system optimisation and design. The use of LCA in marketing is also frequent. A similar survey [72,73] has identified that the main barriers to wider use of LCA in industry are the relatively high costs and the time necessary for carrying out an LCA coupled with uncertainty about the potential commercial benefits.

LCA has also served as a tool for environmental system management and environmental reporting. For instance, in the UK alone there are already over 200 companies which hold the ISO 14001 certificate [74], which means that LCA has been or will be used within the EMS to indicate and track their environmental performance. Unilever, for example, has developed an environmental reporting approach, termed Overall Business Impact Assessment (OBIA) which estimates the emissions associated with the life cycle of a

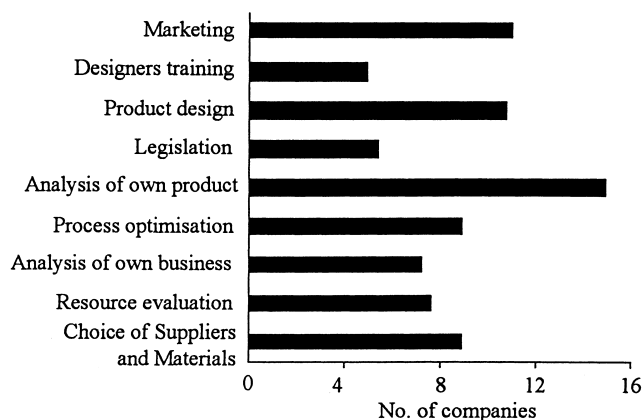

Fig. 4. The uses of LCA by industry (from Baumann [71]).

group of products and business areas [75]. ICI has developed a similar, Environmental Burden approach, using the impact categories in LCA to assess the effects of its activities on the environment [76,77].

End-of-life waste management regulations and cross-sectorial market competition have been the main drivers for LCA activity in European firms [72]. One such example of end-of-life management is packaging legislation [78,79] which requires that certain amount of the packaging must be recycled. Manufacturers of products that may be affected by end-of-life management regulations have tried to influence the regulatory process and the impacts of these regulations in the market by using LCA to support their claims. LCA-based claims have been used in cross-sectorial competition, both by the commodity and final product producers. Examples of these include plastic versus paper packaging [16,80] and phosphates versus perborates in the detergent industry [34].

This trend of increased LCA activity in industry has not been followed by governments, who have been much slower in adopting LCA as a tool in policy making. Although there have been a number of attempts to incorporate LCA in public decision making world-wide, LCA has still not become an integral part of this process. Many governments concentrate on reducing pollution to one medium or from a single life cycle stage. Attempts to integrate life cycle thinking into policy making include EU eco-labelling schemes [81–83], EC directive on Packaging and Packaging Waste [78,79], and the IPPC Directive [3]. Other policies that are starting to use the LCA approach are related to taxation on pollution. One such example is provided by France which introduced a tax on CO₂ emissions based on the results of an LCA study [84]. The Belgian and Norwegian governments are also considering programmes to introduce taxation on packaging for which information has been obtained through life cycle studies. In the USA, the use of LCA in policy making is being encouraged by the EPA through various projects, such as the establishment of subsidies or tax credits for alternative fuels and using a life cycle approach to develop a maximum achievable control technology (MACT) standard under the 1990 Clean Air Act [85].

However, although these schemes promote the use of life cycle approaches in decision making, most of them concentrate only on a limited number of burdens and usually in one or two stages in a life cycle. Nevertheless, this approach is still preferred to single issue considerations, related normally to the recyclability of the product or its biodegradability. Although these examples represent only the beginning of application of LCA in policy making, they are important developments because they demonstrate that governments are starting to consider broader life cycle thinking and are prepared to integrate it into the decision making process.

While a wider acceptance of LCA in policy making is still to come, there are indications that the use of LCA in

industry is constantly increasing [71,74,76,77,85,86]. The rest of this paper reviews and discusses some of these applications, in particular the use of LCA for process selection, design and optimisation.

4. LCA for process selection, design and optimisation

Historically, most of the LCA literature has been product-focused [e.g. [18,36,37,42,80,87–95]]. However, more recently several authors have also demonstrated the so far unexplored potential of LCA as a tool for process selection [96–99], design [100–104] and optimisation [20,24,105–111]. These approaches are discussed in the following section.

4.1. LCA for process selection

In 1997 the U.K. Environment Agency published its guidelines for assessing the ‘Best Practicable Environmental Option’ (BPEO) for processes regulated under Integrated Pollution Control (IPC) [112]. The guidance note sets out a procedure for assessing environmental harm and comparing options for specific industrial processes to determine BPEO. The application of the guidance should enable the environmental consequences (level of harm) of releases to be properly assessed and ensure that the process or abatement option chosen represents the ‘Best Available Technique Not Entailing Excessive Cost’ (BATNEEC) and the site specific BPEO.

However, the approach proposed by the Agency has already attracted criticism, mainly because only site-specific considerations are included in choosing the BPEO. As pointed out by the House of Commons Select Committee on the Environment in connection with regulation of the cement industry [113], this narrow approach impeded the Agency from considering the overall environmental effects as required under the 1995 Environment Act. This criticism emphasized once again the fundamental flaw in the BPEO concept, which only considers emissions from the plant itself, with no account of emissions arising from other sources in the life cycle, such as production of raw materials, transport and waste disposal. Thus it is possible for a BPEO technology to reduce a particular pollutant from a plant, but to increase the emissions of this or other pollutants elsewhere in the life cycle. This has been demonstrated, for instance, by the examples of the end-of pipe abatement techniques for SO₂ [96,98], NO_x [99], and VOCs [99,114]. The findings of these studies confirm that if a real BPEO is to be chosen, it has to be assessed in the LCA context. The importance of LCA for process selection has also been recognised by the EC Directive on IPPC [3], due to be implemented in October 1999 in the member states, which requires that the Best Available Technique (BAT) must be chosen by considering the environment as a whole, including indirect releases, consumption of raw

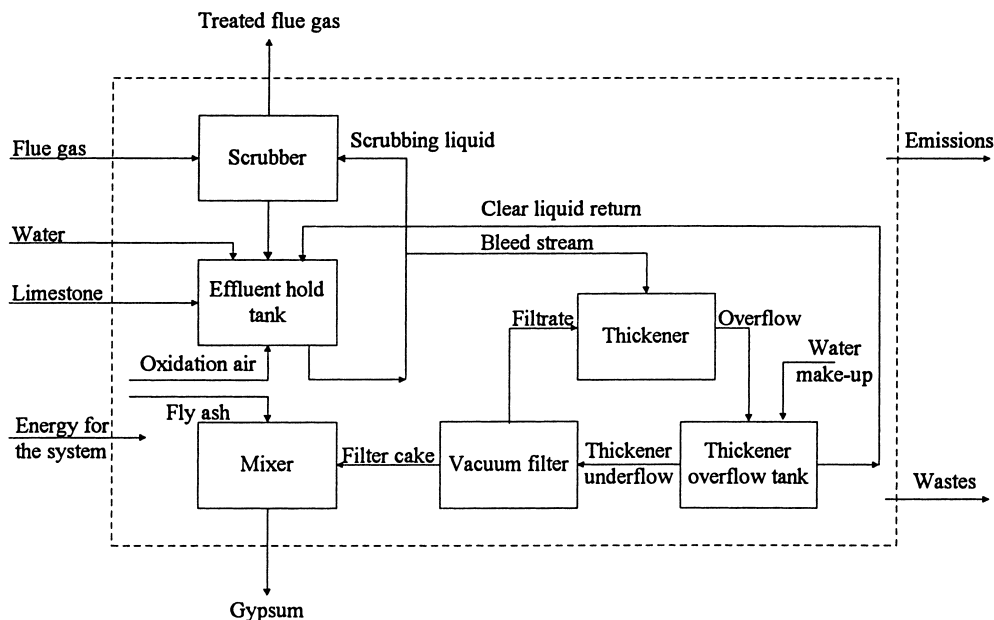

Fig. 5. Life cycle of a wet limestone/gypsum* process (adapted from de Nevers [115]) (*In the double alkali process, sodium carbonate is also added into the thickener overflow tank).

materials and waste disposal. The use of LCA as a tool for identifying BPEO and BAT is now illustrated on several case studies.

4.1.1. BPEO for SO₂ abatement

Vyzi and Azapagic [98] demonstrate, for instance, how LCA can assist in process selection in the context of BPEO by comparing the three most common flue gas desulphurisation (FGD) processes: wet limestone/gypsum, double alkali and dry sodium carbonate processes. In the wet limestone/gypsum process, the sulphur oxides in the flue gas are absorbed in calcium hydroxide to yield calcium sulphate which after dewatering can be used in the construction industry as gypsum (see Fig. 5). The double alkali is similar to the gypsum process, but in addition to calcium carbonate it also uses sodium carbonate. In the dry system, the sodium carbonate particles are injected into the flue gas to react with SO₂ and are then removed, usually in an electrostatic precipitator. Since the purpose of the study is to compare different SO₂ abatement techniques, the functional unit has been defined as 'treatment of one tonne of SO₂ in the flue gas'.

The case study considered in this research is based on the example of Drax, a U.K. coal-fired power station with an output of 4000 MW. The power station burns approximately 430 kg of coal per second with an average content of 2% of sulphur which generates 17 kg/s of SO₂. The wet limestone/gypsum process, which is fully operational at Drax, is designed to remove 90% of the SO₂ emissions from the plant, for which it uses approximately 32.5 kg/s CaCO₃ and produces 48 kg/s gypsum cake. In this way, 482,400 t/year of SO₂ are not emitted into the atmosphere, thus avoiding the associated acidification problem.

However, if this abatement technique is assessed on the basis of LCA, including the environmental burdens of extraction of raw materials, production and transport of CaCO₃ and energy consumption in the process (see Fig. 5), it turns out that additional 900 t/year of SO₂ are emitted elsewhere in the life cycle. Furthermore, a number of other emissions are also generated, of which the most significant is 82,000 t/year CO₂, mainly associated with the life cycle of CaCO₃. Thus, in an attempt to reduce the emissions of SO₂, the acidification problem has been exchanged for global warming. This comes as a direct consequence of a narrow system boundary definition and it clearly demonstrates the drawbacks of not considering the whole life cycle of a process in choosing the BPEO.

However, overall, the wet/gypsum process is still preferred over the other two processes, as it generates the least environmental impacts (Fig. 6). In addition, it produces gypsum as a by-product thus avoiding disposal of solid waste, a problem which remains with the other two processes. The dry system is the poorest option in environmental terms since it would generate 2 million tonnes per year of CO₂ and thus contribute to global warming.

Therefore, it appears that in this case the site-specific and 'cradle to grave' considerations result in the same BPEO, although no LCA was attempted at the time the decision on the best FGD process was being made. One of the motivations for choosing this process as the BPEO then was the assumption that the by-product could be used in the construction industry. This idea is in agreement with the concept of 'industrial ecology', whereby the waste from one system or life cycle becomes an input material into another [116]. However, if all coal-fired stations in the UK followed the same assumption and had limestone FGD, then the

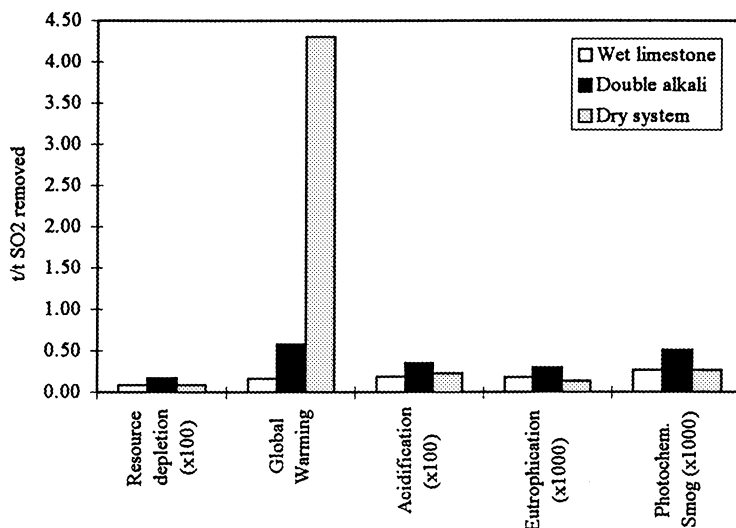

Fig. 6. Comparison of environmental impacts of the FGD systems (from Vyzi and Azapagic [98]).

demand for gypsum would be exceeded and a large amount of solid waste would have to be disposed off instead. Furthermore, a particular difficulty with the Drax gypsum is that it contains a relatively large amount of chloride due to the high chlorine content in the coal, which makes it almost unusable. Under these circumstances, the choice of the gypsum process as the BPEO becomes questionable.

This example therefore shows that the choice of BPEO largely depends on the background economic system within which the process operates. A further illustration of this is provided by Golonka and Brennan [96]. They have shown how the choice of BPEO changes with the way the system boundary is defined in relation to the background system by comparing four options for the treatment of SO_2 from metallurgical smelters. The processes assessed have included the production of sulphuric acid, elemental sulphur, saleable gypsum and disposable calcium sulphite sludge. Following the LCA philosophy, the authors have also considered the environmental impacts of the downstream processing of the by-products of the desulphurisation processes, i.e. sulphuric acid and elemental sulphur, when used to manufacture either single superphosphate (SSP) or diammonium phosphate (DAP).² In the analysis without the downstream processing, the H_2SO_4 process was found to be the BPEO in terms of resource depletion and acidification (Fig. 7). In terms of global warming, the elemental sulphur process was preferred as it generated $-140 \text{ kg CO}_2 \text{ eqv/t SO}_2$ (the negative value is due to the heat recovery from the process). The gypsum and disposable sludge processes were the worst options as they contributed to global warming in the order of 1 tonne of $\text{CO}_2 \text{ eqv}$ per tonne of SO_2 removed.

²Both SSP and DAP processes use sulphuric acid as a raw material, hence elemental sulphur must first be converted to sulphuric acid. DAP also requires the production of phosphoric acid as an intermediate. These two processes have been chosen as they represent the most common uses of H_2SO_4 worldwide [96].

However, if the background system related to downstream processing of elemental S and H_2SO_4 is included within the system boundaries, i.e. in effect brought into the foreground, then $\text{H}_2\text{SO}_4 + \text{SSP}$ and $\text{H}_2\text{SO}_4 + \text{DAP}$ become worse options for resource depletion, having three orders of magnitude higher impact than, for instance limestone scrubbing. In terms of global warming, $\text{H}_2\text{SO}_4 + \text{DAP}$ is worse than gypsum and sludge, while the elemental S + SSP process now represents the best environmental option (see Fig. 7). Similar to the findings of the FGD case study, this comparison also demonstrates that the system boundary is of key importance in choosing BPEO. Furthermore, it also shows how LCA ensures the link to industrial ecology by considering entire energy and material supply chain along the life cycle of a product or process.

4.1.2. BPEO for NO_x abatement

Other authors have also demonstrated the value of LCA as a tool for choosing BPEO for clean-up processes. Yates [99], for instance, has compared the end-of-pipe technologies for abatement of NO_x from metal dissolution processes in the electronics and nuclear industries. Four technologies, suitable for treating mixtures of $500\text{--}5000 \text{ mg/m}^3$ of NO_2 and NO in the inlet gas down to 300 mg/m^3 , were neutralisation with NaOH, extended absorption in water, selective catalytic reduction, and adsorption onto zeolite. Neutralisation of NO_x in NaOH in a packed column, in which the NO_x gas reacts with NaOH yielding an aqueous sodium nitrite–nitrate effluent, is at present the most widely used technique for NO_x abatement. However, although very efficient in removing NO_x , this method generates liquid waste and therefore transfers the burdens from one medium to another. In the extended absorption process, the efficiency of a single water absorption plant is improved by the addition of a second tower in a series with the existing column. To minimise the size of the additional absorption tower, the inlet gas is pressurised and absorbed in chilled water, to

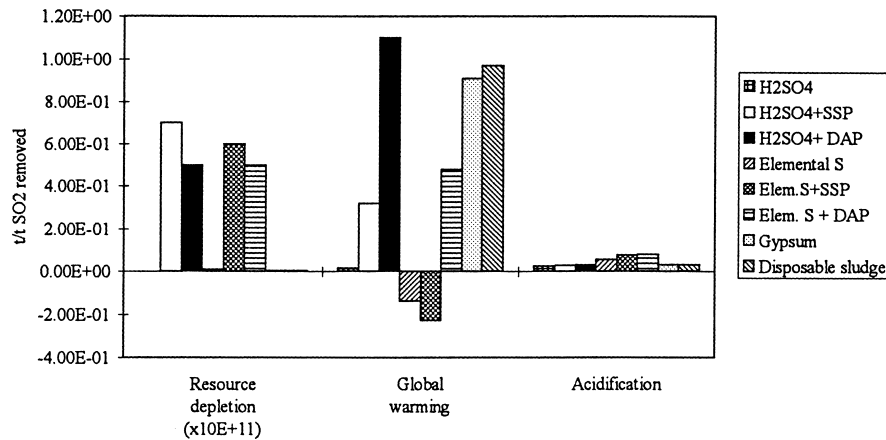

Fig. 7. LCA comparison of options for the treatment of SO_2 from metallurgical smelters (from Golonka and Brennan [96]).

yield nitric acid which can then be used in the dissolution process. Selective Catalytic Reduction (SCR) reduces NO_x gases to nitrogen and water by reaction with ammonia over a catalyst at a temperature of 250°C . A considerable amount of heat can be recovered to be reused in the process. Adsorption onto zeolite is carried out by continuous adsorption/desorption of the NO_x on to a packed bed of zeolite.

Regeneration of the zeolite is achieved by heating the bed with steam to remove rich NO_x fumes which can be absorbed in water to yield nitric acid. Although very promising, this technique is still not available commercially. The life cycles of these techniques, encompassing all activities from extraction and manufacture of raw materials to generation and use of energy, are shown in Fig. 8 [99].

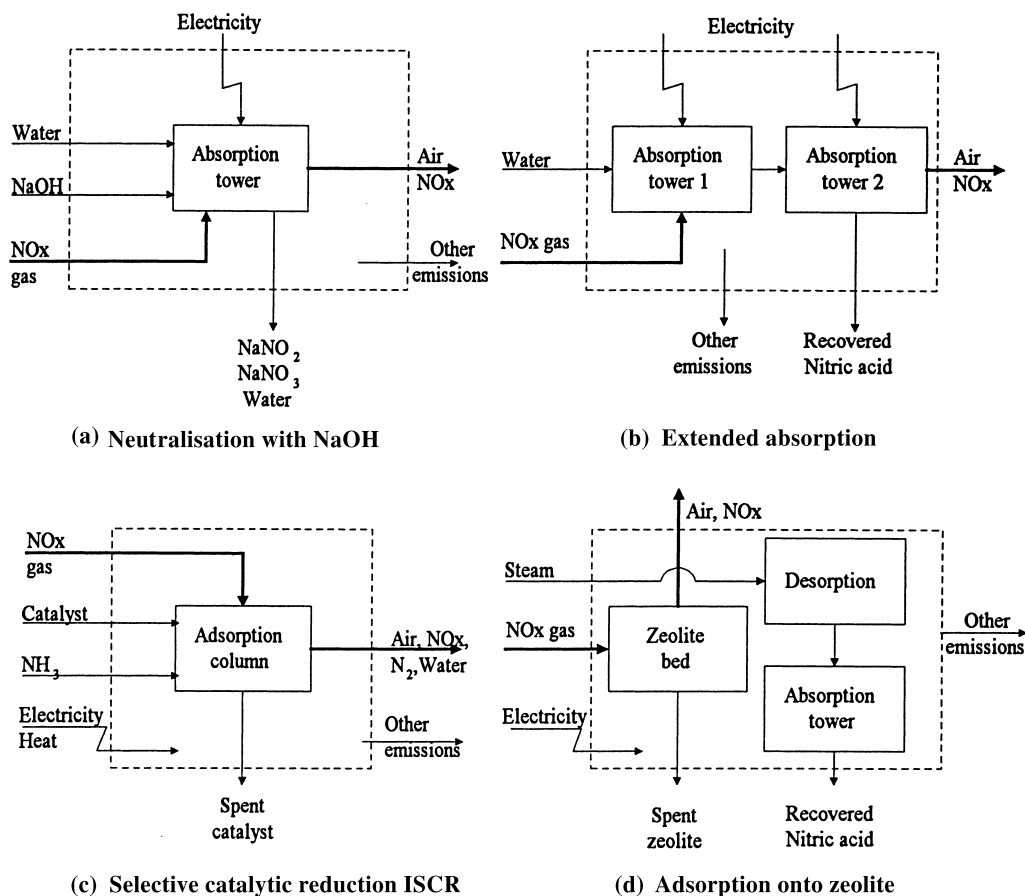

Fig. 8. LCA flow diagrams of the NO_x abatement techniques (adapted from Yates [99]).

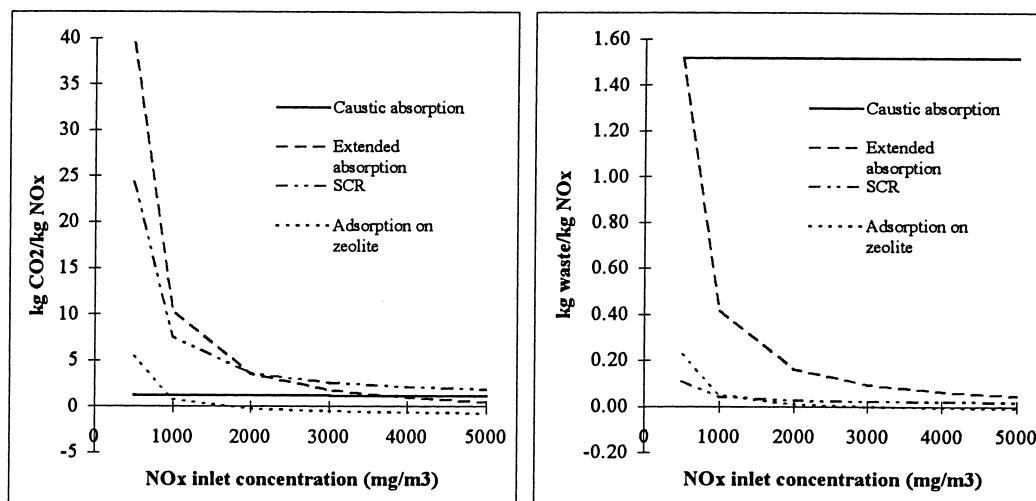

Fig. 9. Life cycle CO₂ emissions and waste for NO_x abatement technologies (from Yates [99]) (Flow rate: 10000 m³/h, outlet NO_x conc. 300 mg/m³; Adsorption onto zeolite: zeolite loading = 0.14 g/g; Extended absorption: system pressure = 100,000 N/m²).

The results of LCA suggest that over the concentration range of 500–5000 mg/m³ the most favourable NO_x abatement technology for all burdens is adsorption onto zeolite. As shown in Fig. 9, this technique has negative emissions (only CO₂ has been shown since the trends are the same for other emissions) and wastes due to the recovery of nitric acid from the desorbed NO_x, which avoids the need to manufacture it elsewhere. Only at NO_x inlet concentrations below 1000 mg/m³ do the burdens become positive. However, this technology is not at present available commercially, so the next best available option is caustic scrubbing. This technique is, however, let down by the high quantities of waste sodium nitrate/nitrite generated as a by-product: 1.5 kg/kg NO_x removed, compared to an average of 0.04 kg/kg NO_x for catalytic reduction. This then leaves SCR and extended absorption which exhibit similar values for the burdens over the life cycle for NO_x concentrations above 2000 mg/m³. Below that, their environmental impacts increase significantly (see Fig. 9). For instance, a treatment of 500 mg/m³ NO_x in the SCR and the extended absorption process generates 25 and 40 kg of CO₂ per kg of NO_x removed over the whole life cycle. Thus, the best *practicable* environmental option overall appears to be either SCR or extended absorption for concentrations above 2000 mg/m³, whilst zeolite adsorption remains the best option over the whole range of concentrations examined. These findings therefore confirm a generally accepted belief that recovery and reuse of pollutants are more environmentally beneficial than the non-recovery options. However, the choice of the best technique will depend on the specific characteristics of the process such as gas flowrate and the concentration of the pollutant in the waste stream.

4.1.3. BPEO for VOC abatement

Yates reached similar conclusions in an LCA study of the end-of-pipe technologies for VOC removal from a dyestuffs

manufacturing plant [99]. The case study investigated the effect of flow rate (1000–20,000 m³/h) and concentrations of mainly xylene (200–1200 mg/m³) in the waste stream on the choice of BPEO. Four techniques were examined: activated carbon adsorption with steam regeneration (ACA-SR), catalytic oxidation (CO), cryogenic recovery (CR) and biological oxidation (BO). Since the ACA-SG had previously been identified as the BPEO without using LCA principles, the study re-examined this choice and compared it with the other three techniques.

In the ACA-SR process, steam is used to regenerate the carbon bed and recover xylene in situ. The desorbed VOC off-gas stream is condensed to yield a water/organic mixture which is then phase-split. The catalytic oxidation process destroys gaseous VOCs through oxidation over a catalyst at temperatures of 250–350°C. Efficient heat recovery from the oxidation of VOC usually satisfies the heat requirements of the system and avoids the need for additional heat supply. Cryogenic recovery, on the other hand, operates by lowering the temperature of the gas stream below the VOCs' dew point. Temperatures as low as –150°C can be reached by using liquid nitrogen. If the VOC condensate is of a sufficient purity, i.e. contains mainly one component, it may be recovered directly for reuse. Finally, the biological treatment utilises bacteria to oxidise organic material in the liquid phase. The life cycles of these processes are shown in Fig. 10.

It was found that in terms of CO₂, NO_x, and VOC emissions, ACA-SR was the preferable option over all flow rates and concentrations investigated; furthermore, these emissions were negative due to the recovery of xylene and the associated avoided burdens, which would otherwise arise from the energy-intensive primary production of this solvent (Fig. 11). The only burden for which this process was not the BPEO was SO₂; however, the difference between this and the other processes was small and could be neglected. This again points to the conclusion that

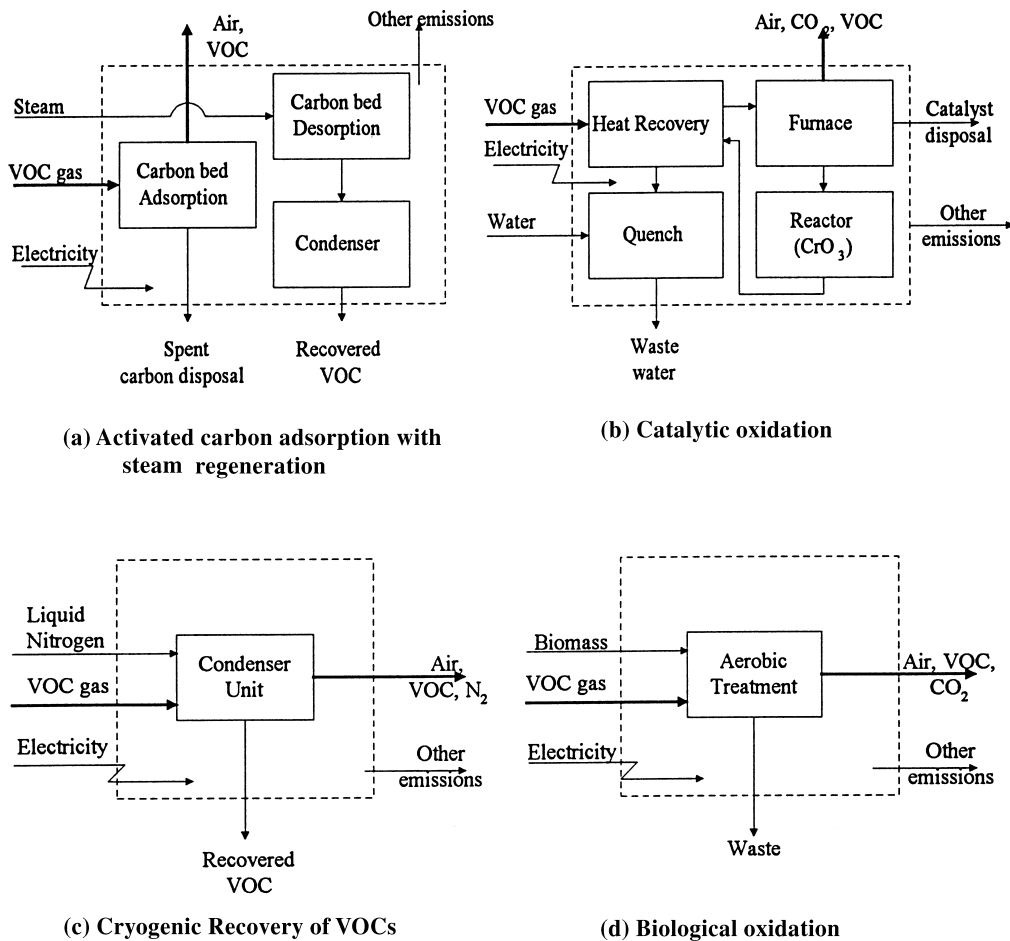

Fig. 10. Life cycles of VOC abatement techniques (adapted from Yates [99] and Meier [114]).

recovery of a pollutant is an environmentally better option than destroying it.

A counter-example is provided by the cryogenic recovery process, which was found to be the worst option for most

of the environmental burdens. The main reason for this is a high energy requirement for the production of liquid nitrogen, which exceeds the benefits of VOC recovery. However, as the amount of VOC recovered increases, the

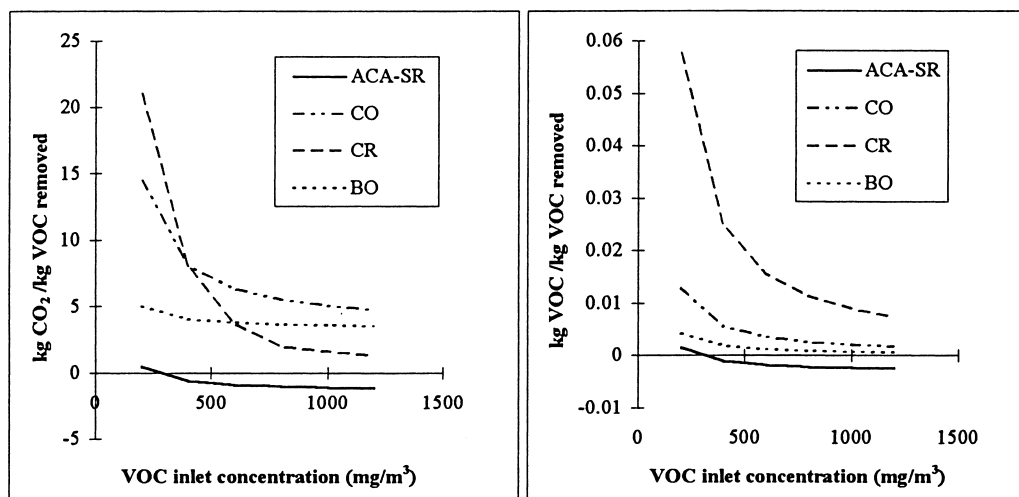

Fig. 11. Life cycle CO₂ and VOC emissions for VOC abatement technologies (from Yates [99]) (Flow rate: 5000 m³/h, Outlet VOC conc. 50 mg/m³; Catalytic oxidation: $T_{\text{oxidation}} = 350^{\circ}\text{C}$; Cryogenic recovery: $T_{\text{cooling}} = -50^{\circ}\text{C}$).

cryogenic process becomes more competitive and, for inlet VOC concentrations above 600 mg/m^3 , it becomes the second most favourable option to ACA-SR in terms of CO_2 emissions (see Fig. 11). Furthermore, in cases where the existing nitrogen usage elsewhere on site is sufficient to meet the VOC recovery demand, the environmental burdens of CR approximate those of ACA-SR [99]. Thus depending on the operating conditions of the foreground and the activities in the background systems, the CR process ranges from being the worst option to representing the BPEO.

In a similar LCA study of VOC abatement techniques, which considered activated carbon adsorption, catalytic oxidation and biological filtration, Meier [114] shows how the choice of BPEO changes if the waste gas instead of one compound contains a mixture of 20 different VOCs. Since the VOCs are not recovered but incinerated in the activated carbon process considered in this study, there are no avoided burdens for the primary manufacture of the VOCs and additional emissions are generated by the incineration. For instance, the total CO_2 emissions are in this case equal to 23.9 kg/kg VOCs removed, in comparison to 0.5 kg/kg in the ACA-SR process for the same VOC concentration in the flue gas of 200 mg/m^3 . A similar increase is observed for the other burdens so that the activated carbon process no longer represents the BPEO and the biological filter becomes the best option. Thus, this is another instance where industrial ecology, i.e. the possibility of re-using waste materials, influences the choice of BPEO. This study also included economic evaluation of the three options to identify BATNEEC; biological oxidation was found to be the best option overall. Since there was little difference between the activated carbon and catalytic oxidation processes in terms of environmental performance and catalytic oxidation had lower economic costs, the latter was the second preferred option overall after the biological filter.

4.1.4. BPEO for liquid CO_2 and O_2 production

The application of LCA for process selection is not limited to end-of-pipe techniques only, as demonstrated by a number of LCA studies of various industrial processes. For instance, Rice [97] shows the usefulness of LCA in process selection on an example of the production of liquid carbon dioxide. Three sources of CO_2 were compared: chemical waste gas, a natural deposit and fossil fuel combustion. The waste CO_2 in this example arises from the ICI ammonia plant and if it was not utilized as a by-product it would normally be released into the atmosphere. The second source of CO_2 considered in this work is from a natural deposit, while the third source is via combustion of fossil fuel (kerosene). The CO_2 from all the three sources is cleaned, compressed and liquefied before its downstream use which, in Rice's case, included aeration of soft drinks. The results of the analysis showed that in terms of global warming, the best environmental option is to source raw CO_2 from chemical waste gas. This reduces the ultimate volume of CO_2 that would otherwise be released into the atmosphere and ensures that the utilization efficiency associated with the system is high. However, as shown in Fig. 12, in terms of all other impacts, CO_2 from natural gas is environmentally the best option. Sourcing the liquid CO_2 from fossil fuel is the worst option overall as it has the highest environmental impacts.

Rice took this analysis further to show the importance of the upstream CO_2 process selection for the total environmental impacts when the system boundary is extended to include the use of CO_2 [97]. If CO_2 is used as an input material into a system of relatively low energy intensity, the selection of the process for its generation can play an important role. For instance, when used for a water softening treatment, the source of the CO_2 becomes an important factor in the overall impact of the treatment system. If, on the other hand, the liquid CO_2 is an input for a process of relatively high energy intensity, the source of the CO_2

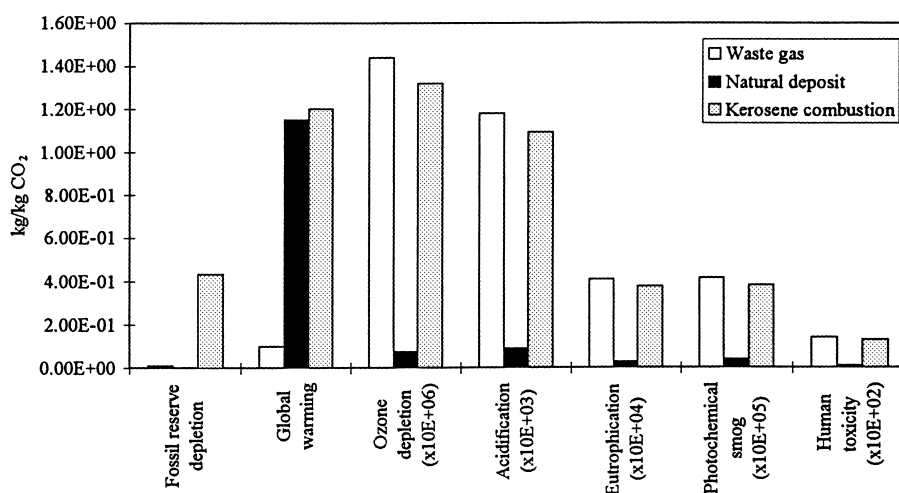

Fig. 12. Environmental impacts of the processes for generation of liquid CO_2 (from Rice [97]).

becomes much less important. One such example is the use of CO₂ in the soft drinks industry, where the impacts of CO₂ generation become negligible in comparison to the process of manufacturing soft drinks. These two examples are particularly interesting as they demonstrate that if a BPEO that benefits the environment as a whole is to be identified, it has to be done on a case-specific basis. In policy terms, this suggests that in choosing BPEO it would seem appropriate to move away from prescriptive legislation with set limits and hierarchies to a more flexible approach which allows assessment of different options on a case-by-case basis. This view has already been adopted by the IPPC Directive, which recommends that the “emission limit values, . . . or equivalent technical measures should be based on the best available technologies [BATs], without prescribing the use of one specific technique or technology and taking into consideration the technical characteristics of the installation concerned, its geographical location. . . and the environment as a whole” [3].

Rice [97] also showed how the choice of BPEO can depend on some of the factors identified by the IPPC, including technical characteristics, geographical location, the scale of operation etc. He compared processes for production of oxygen used for aeration of activated sludge in waste water treatment. The alternative technologies considered were liquid O₂ from small (140 t/day) and large scale (600 t/day) cryogenic air separation units (ASU), gaseous O₂ from pressure swing adsorption (PSA), and gaseous O₂ from a vacuum swing adsorption (VSA) unit. The results showed that per kg of O₂ at the point of use, the best environmental alternative is to generate O₂ in a cryogenic unit and deliver it to the point of use. As economies of scale play a significant role, it was found best to source O₂ in a large-scale ASU. The choice of BPEO is also affected by O₂ demand. If the oxygen requirement is between 20 and 70 t/day, ASU remains the best option for delivery distances smaller than 1000 miles. Above that, an on-site VSA becomes the best environmental option. PSA units are only attractive if the demand for O₂ is less than 20 t/day (i.e. below the minimum VSA production level) and the delivery distance is greater than 1500 miles.

Furthermore, Rice [97] shows how process efficiency can influence the choice of BPEO by comparing the life cycles of air-based mechanical aeration techniques (fine and coarse bubble-diffused air aeration, jet aeration and surface paddle aeration) with an oxygen-based technology (VitoxTM) used in the activated sludge process. If the VitoxTM technology, with oxygen sourced from the large-scale ASU, is operated at the design capacity of 2.5 kg O₂/kWh of energy needed to supply O₂, it is clearly the best environmental option ahead of the fine bubble, jet aeration, coarse bubble and paddle aeration options, respectively. However, if the operation of VitoxTM moves away from the design capacity, the associated life cycle impacts increase so that at the energy efficiency of 0.9 kg O₂/kWh, its overall impact becomes second only to paddle aeration and fine bubble and jet aeration systems now represent the BPEO.

The above examples demonstrate the usefulness of LCA for process selection. If applied correctly, this approach can ensure that the best environmental option is identified throughout the life cycle. However, in many cases, possibilities for further improving and optimising the performance of the selected process will exist. Life cycle thinking can also be applied to identify optimum options for process improvements. The application of LCA to system optimisation is the subject of the next section.

4.2. Process optimisation

Traditionally, system optimisation in chemical and process engineering applications has focused on maximising the economic objectives. Over the past 10 years, considerations for improving the environmental performance have started to be integrated into system optimisation alongside economic criteria. These included various waste minimisation approaches from the concept of mass pinch as a tool to derive cost-optimal Mass Exchange Networks with minimum emissions waste [117], through minimum waste water generation in process plants (e.g. [118]) and waste treatments costs [119,120], to the concept of Zero Avoidable Pollution [121,122]. Although these approaches may have both environmental and economical benefits through reduced wastes and costs of treatment [123], their disadvantage is that they concentrate on emissions from the plant only, without considering other stages in the life cycle. More recently, life cycle thinking has started to be incorporated into the process design and optimisation procedures [20,24,101–111], thus establishing a link between the environmental impacts, operation and economics of the process [100]. These developments are still underway and the published literature on this subject is quite limited.

In general, the approach for incorporating LCA into system optimisation comprises three main steps [20,24,106–111]:

- (i) Carrying out a Life Cycle Assessment study;
- (ii) Formulation of the multi-objective optimisation problem in the LCA context;
- (iii) Multi-objective optimisation and choice of the best compromise solution.

(i) The methodology for the first step of the procedure has been briefly explained in Section 2; a more detailed account can be found in Consoli [19], Fava [18] and the ISO 14040 series [17].

(ii) The optimisation problem in the context of LCA is equivalent to a conventional optimisation model except that in addition to an economic function it also involves environmental objectives, represented by the burdens or impacts. Thus a single objective optimisation problem is transformed into a multi-objective one. The system is optimised simultaneously on both economic and environmental performance, subject to certain constraints encompassing all

activities from cradle to grave. This results in an n -dimensional non-inferior or Pareto surface with a number of optimum solutions for system improvements. By definition, none of the objective functions on the Pareto surface can be improved without worsening the value of any other objective function. Therefore, some trade-offs between objective functions are necessary in order to reach the preferred optimum solution in a given situation. Evaluation of trade-offs and elicitation of preferences to identify the best compromise solution is part of step (iii), as discussed later in the paper.

In general, a multi-objective optimisation (MO) problem of a system formulated in the LCA context can take the following form:

$$\begin{aligned} \text{Minimise } & \mathbf{f}(\mathbf{x}, \mathbf{y}) = [f_1 \ f_2 \ \dots \ f_p] \\ \text{s.t. } & h(\mathbf{x}, \mathbf{y}) = 0 \\ & g(\mathbf{x}, \mathbf{y}) \leq 0 \\ & \mathbf{x} \in \mathbf{X} \subseteq \mathbf{R}^n \\ & \mathbf{y} \in \mathbf{Y} \subseteq \mathbf{Z}^q \end{aligned} \quad (1)$$

where \mathbf{f} is a vector of economic and environmental objective functions; $h(\mathbf{x}, \mathbf{y}) = 0$ and $g(\mathbf{x}, \mathbf{y}) \leq 0$ are equality and inequality constraints, and \mathbf{x} and \mathbf{y} are the vectors of continuous and integer variables, respectively. Equality constraints may be defined by energy and material balances; the inequality constraints may describe material availabilities, heat requirements, capacities etc. A vector of n continuous variables may include material and energy flows, pressures, compositions, sizes of units etc., while a vector of q integer variables may be represented by alternative materials or technologies in the system or a number of trucks for transport of raw materials. If the integer set \mathbf{Z} is empty and the constraints and objective functions are linear, then (1) becomes a Linear Programming (LP) problem; if the set of integer variables is nonempty and nonlinear terms exist in the objective functions and constraints, formulation (1) is a mixed-integer nonlinear programming (MINLP) problem. Mixed integer linear programming (MILP) problems incorporate integer and linear variables only.

An economic objective typically involves a cost or profit function as defined by:

$$\text{Minimise } F = \mathbf{c}^T \mathbf{y} + f(\mathbf{x}) \quad (2)$$

where \mathbf{c} is a vector of cost or profit coefficients for integer variables and $f(\mathbf{x})$ is a linear or non-linear function related to continuous variables. The environmental objectives in this context represent the burdens B_j or impacts E_k :

$$\text{Minimise } B_j = \sum_{n=1}^N b_{j,n} x_n \quad (3)$$

$$\text{Minimise } E_k = \sum_{j=1}^J ec_{k,j} B_j \quad (4)$$

where $bc_{j,n}$ represents emission coefficients associated with continuous variables x_n . In Eq. (4), $ec_{k,j}$ represents the

relative contribution of burden B_j to impact E_k , as defined by the ‘problem-oriented’ approach to Impact Assessment [36]. In this approach, for example, Global Warming Potential (GWP) factors, $ec_{k,j}$, for different greenhouse gases are expressed relative to the GWP of CO_2 , which is therefore defined to be unity. If a different Characterisation approach is used, then Eq. (4) may be redefined accordingly. Note that at present the LCA approach assumes that environmental burdens and impacts functions are linear, i.e. they are directly proportional to the output of functional unit(s) and there are no synergistic or antagonistic effects.

Depending on the characteristics of the system, the problem (1) can be formulated as (mixed integer) linear or nonlinear. The theory for solving such problems is well established (e.g. [124,125]) and a number of commercial software packages are available to deal with large-scale problems, of which GAMS [126] is probably the most widely used in process and chemical engineering applications. Literature on techniques for solving general single objective optimisation problems is plentiful (e.g. [124,125,127]); multi-objective optimisation problems have also been extensively reviewed (e.g. [128,129]).

(iii) The system is then optimised on a number of objective functions and optimum solutions are found on the multi-dimensional non-inferior or Pareto surface. Which environmental objectives will be chosen for optimisation depends on the Goal and Scope of the study. Thus, optimisation can be performed either at the Inventory or Impact Assessment levels, in which case the environmental objectives are defined as either burdens or impacts, respectively. Hence, local and global system improvements are found by first moving the system to conditions on the Pareto surface, and then moving on it. As already mentioned, all objectives on the surface are optimal in the Pareto sense and some trade-offs between the objectives are necessary to identify the best compromise solution. For example, if the system is optimised simultaneously on two objectives — one economic and one environmental — the resulting Pareto optimum does not necessarily mean that these functions are at their respective optima achieved when the system is optimised on each of them separately (see Fig. 13). The Pareto

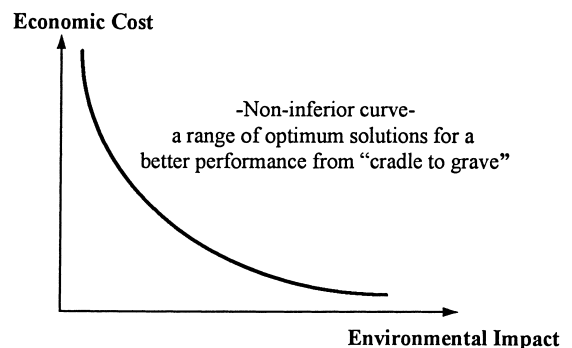

Fig. 13. Pareto curve obtained in multi-objective optimisation (from Azapagic [20]).

optimum, however, does mean that the set of best possible options has been identified for a system in which both objectives should be improved.

Ultimately, environmental and economic objectives could be aggregated into a single function by attaching weights to indicate their importance, so that the problem reduces to a single objective one. However, the main advantage of MO is that it does not require a priori articulation of preferences, so that the whole non-inferior set of solutions can be explored. The emphasis then is on the range of choices from the set of non-inferior solutions, rather than explicit definition of preferences before analysing all the trade-offs among objectives. The trade-offs show explicitly what can be gained and what lost by choosing each alternative. Where there are multiple decision makers with conflicting interests, this technique can help to resolve disputes by generating different alternative solutions. Decision makers who understand the trade-offs and the alternatives are more likely to understand the interests of other parties and, therefore, to compromise. Although the evaluation of trade-offs among the objectives to choose the best compromise solution will still imply certain preferences and value judgments, at least the choice will be made from all possible non-inferior solutions, unlike other methods where the bulk of non-inferior solutions may be ignored. This is particularly relevant in the LCA context, because it enables avoiding the controversial and debatable concept of aggregation of environmental impacts into a single environmental impact function in the Valuation stage. Furthermore, by being able to trade-off incommensurable objectives, e.g. environmental impacts and economic requirements, this approach avoids the well-known problems encountered, for instance, in cost–benefit analysis [130–133], i.e. reducing individual preferences to a market value or trying to express the quality of the environment in financial terms.

One of the possible ways to choose the ‘best’ solution is to consider a graphical representation of the non-inferior set and then choose the best compromise solution on the basis of the trade-offs. However, this approach is limited to two or three objective functions at most, because graphical representation becomes less than helpful with more than three objectives. Another way to look at it is to express the values of objectives at non-inferior solutions in terms of the percentage distance from their individual optima. If all objectives are considered to be of the same importance, then the best compromise solution could be that which equalizes the percentage by which all objectives differ from their optimum values. However, should any of the objectives be considered more important than the others, then other techniques that allow ordering of preferences, such as Multi-attribute Utility Theory [134] or Analytic Hierarchy Process [135], could be used to identify the best compromise solution. Although this implies eliciting preferences for the objectives, these preferences are at least articulated in the post-optimal analysis of all non-inferior solutions and their

trade-offs, as distinct from expressing preferences and aggregating the objectives prior to identifying all non-inferior solutions.

An approach similar to this was used by Kniel et al. [100] for the optimisation of a nitric acid plant. The plant produces roughly 30 t of 56% nitric acid per hour and generates 107 kg/h nitrogen oxides in the waste gas. To improve the environmental performance of the plant, two process alternatives to the basic design were considered: addition of a SCR unit and increasing the operating pressure in the nitric acid absorber. LCA identified the latter alternative as environmentally superior to both the existing operations and the installation of a SCR unit. Economic analysis revealed that the rate of return was comparable to that of the existing operations and about 28% higher than that of the SCR. To illustrate the approach, the system was optimised on two objectives: economic returns and environmental index function. The latter represented a linear combination of impacts, aggregated by using the marginal values which relate changes in the environmental impacts to process variables and are obtained at the solution of the optimisation problem. As discussed above, one of the drawbacks of the a priori aggregation of objectives is that a number of non-inferior solutions could be lost before considering the trade-offs. Furthermore, as acknowledged by the authors, the aggregation method used in this particular case is based on the way the system is operated and fails to include the sociological aspects into valuation.

As illustrated in Fig. 14, the Pareto curve shows the trade-offs between the environmental index and the economic returns, depending on pressure in the system. The environmental index reaches a minimum when pressure is maximum because recovery of NO_x is maximised. The maximum economic return occurs at an intermediate pressure, where recovery of NO_x is relatively high, but compression costs are relatively low. It is also interesting to note that in this case the curve flattens in its upper regions, suggesting that a slight increase in operating pressure would cause little economic sacrifice but substantial environmental benefit. As discussed above, this quantification of losses and gains provides a useful tool to the decision makers in choosing the best compromise solution.

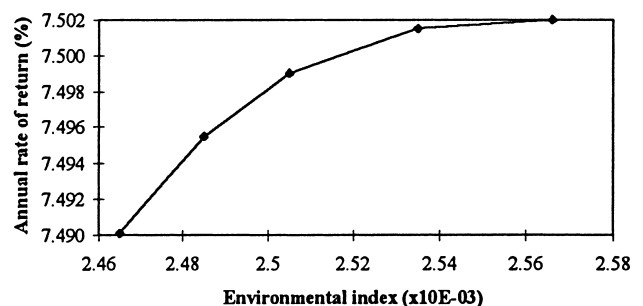

Fig. 14. Non-inferior curve for optimisation of a nitric plant (from Kniel et al. [100]).

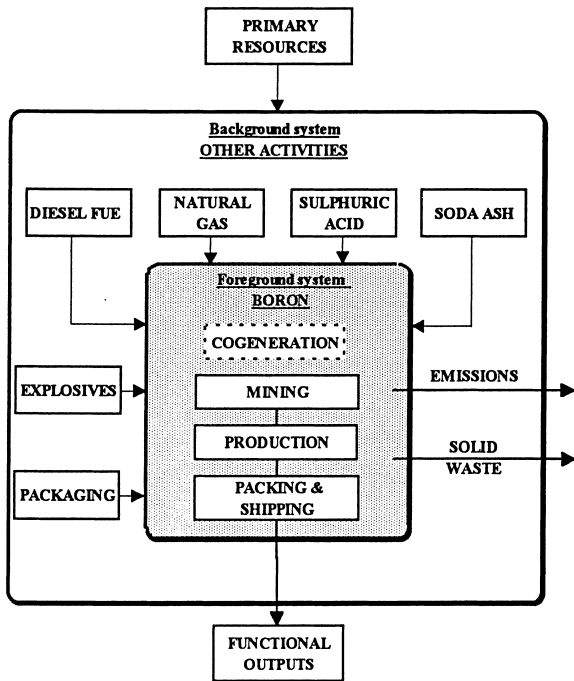

Fig. 15. LCA flow diagram of the boron system (from Azapagic and Clift [110]).

Azapagic [20] and Azapagic and Clift [136,137] have taken this approach further by optimising on a number of environmental and economic objectives, thus avoiding Valuation. This is illustrated on a real mining and processing example of the system producing five boron products: 10 mol borate ($\text{Na}_2\text{B}_4\text{O}_7 \cdot 10\text{H}_2\text{O}$), 5 mol borate ($\text{Na}_2\text{B}_4\text{O}_7 \cdot 4.67\text{H}_2\text{O}$), boric acid (H_3BO_3), anhydrous borax ($\text{Na}_2\text{B}_4\text{O}_7$), and anhydrous boric acid (B_2O_3). A simplified LCA flow diagram of the system, showing the distinction between the foreground and background subsystems, is shown in Fig. 15. After extraction and crushing, the boron minerals,

borax and kernite, are transported to the plant and dissolved in water to produce 5 and 10 mol borates. Boric acid (BA) is produced in a separate plant, by reacting kernite ore with sulphuric acid. Anhydrous borax (AB) and anhydrous boric acid (ABA) are made in high-temperature furnaces from 5 mol borate and BA, respectively. All products are then either packed or shipped in bulk. Electric energy and steam for the system are provided by the on-site natural gas cogeneration facility with additional steam generated in the steam plant. All activities from the extraction of raw materials to the production of the boron products and materials used are included in the system; however, the use and disposal phases of the products are not considered in this study ('cradle-to-gate' approach). The functional unit was defined as total yearly production of the boron products of 1,062,000 t/year.

The objective of this work was to optimise the system on environmental and economic performance to identify a range of possibilities for minimising total environmental impacts from the system, while maximising production subject to total product demand and keeping the production costs to their minimum. The optimisation model also included several process alternatives to identify the BPEO. These included different product dryers (fluid, tray and rotary), conveyors instead of trucks in the mine, and the generation of additional steam in the Cogeneration instead of in the Steam plant. To demonstrate the approach, the system model defined by Eqs. (1)–(4), was optimised on three objective functions: global warming potential (GWP), total production (P) and production costs (C). The three-dimensional non-inferior surface ABCD, generated in a series of multi-objective optimisations, is shown in Fig. 16. Depending on the position on the non-inferior surface, the optimum solutions offer different options for improvements and BPEOs. For instance, Point A represents the minimum of the cost-objective function; however, the

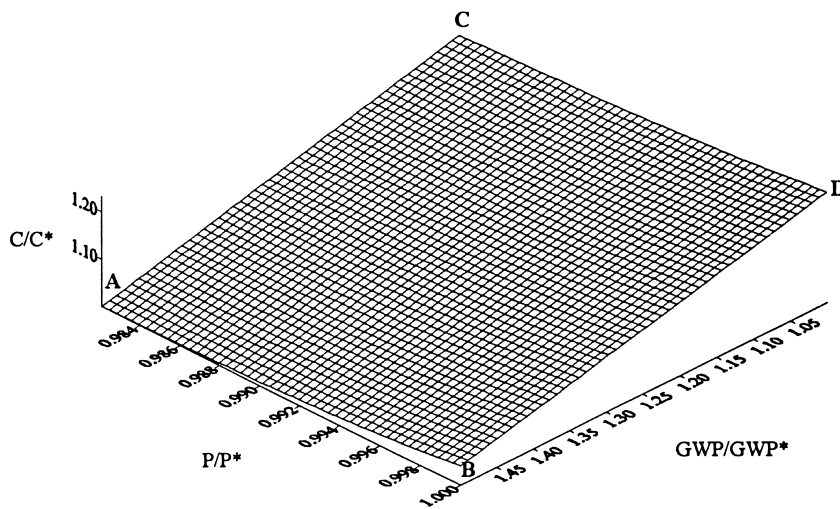

Fig. 16. Non-inferior surface for the boron system (from Azapagic [20]) (C^* , GWP^* and P^* — optimum values obtained in single-objective optimisation; C , GWP , P — optimum values obtained in multi-objective optimisation).

production is at the minimum and GWP is 31% above its optimum value. The BPEO at this point includes transport in the mine by trucks and steam production in the Steam plant. The Kuhn–Tucker multipliers³ at this solution suggest that if a further decrease in the GWP objective by one tonne is required, a cost increase of £95 would be incurred for constant product output; similarly, if the production were to increase by one tonne, the resulting increase in the costs would be equal to £34 for constant GWP. The Kuhn–Tucker multipliers therefore determine the marginal costs of reducing GWP and increasing production, respectively.

By moving from Point A along the non-inferior curve for constant GWP, both costs and production increase, to reach their maximum feasible values at point B. The Cost function here is 4% above its optimum value. If Production is increased by one tonne, £300 of the Costs objective have to be given up. Similarly, one tonne change in GWP is associated with a cost change of £100. At this solution, the BPEO is defined by steam generation in the Steam plant and the preferred transportation means in the mine is by conveyors.

If, however, the system were to be operated at Point C, GWP would be 3.3% above its optimum value obtained in single objective optimisation. Production would be at the minimum, and the costs would increase by 14%. An improvement in GWP of one tonne would worsen the values of the Costs objective by £36, while a tonne increase in P would result in £100 increase in the costs. At this point, 93% of the steam is generated by the Cogeneration plant and the rest is produced in the Steam plant. The conveyors still remain the best transport option in the mine.

Furthermore, if, for example, Point D were to be chosen as the best compromise solution, then for the same value of GWP as at Point C, production would reach the maximum; however, costs would have to increase by 17%. It can be noted here that both GWP and Production exhibit similar effect on Costs: a decrease in GWP by one tonne increases Costs by £3,600, while increasing production by one tonne, increases the costs by £3,500. At this solution, the best practicable environmental option is defined by truck transport in the mine and steam production in the Cogeneration plant.

These results demonstrate how optimum solutions and therefore BPEO change with the operating state of the system. The same analysis can be done for other points on the non-inferior surface which are all optimal in the Pareto sense. By trading-off the values of different objectives at these points, decision makers can select any solution on the surface, depending on how much of one objective they are prepared to give up in order to gain in another. The value of multi-objective optimisation in the context of LCA, therefore, lies in offering a range of choices for environ-

mental and economic improvements of the system and so enabling preferences to be identified after analysing all the trade-offs among objectives.

Although the discussion in this section has mainly focused on optimisation of the existing processes, a similar approach can be applied for the design of new processes. The use of LCA and multi-objective optimisation in the process design is reviewed in the next section.

4.3. LCA for process design

One of the newly emerging applications of LCA is in product and process design. This has resulted in the development of a new LCA-related tool — Life Cycle Product/Process Design (LCPD). The LCPD methodology is still in its infancy and published literature is scant (e.g. [92,94,138]).

Although the methodologies for life cycle product and process design are similar, the following discussion will focus on Life Cycle Process Design. As outlined in Fig. 17, environmental considerations are incorporated at an early stage of the design, alongside the more traditional technical and economic criteria [139]. LCA is used throughout the design process, initially on a reference process. The conventional system boundary is extended to include the life cycles of different technologies and raw materials, all the way from extraction of primary resources through to production. This enables a quantitative comparison of different technological routes for production of the same set of raw materials as well as an assessment of different raw materials. It may be noted that the same rigorous flowsheeting procedures used in conventional design can directly be linked with the environmental analysis described here. Furthermore, as Product Stewardship initiatives are seeking to build alliances between manufacturers and suppliers

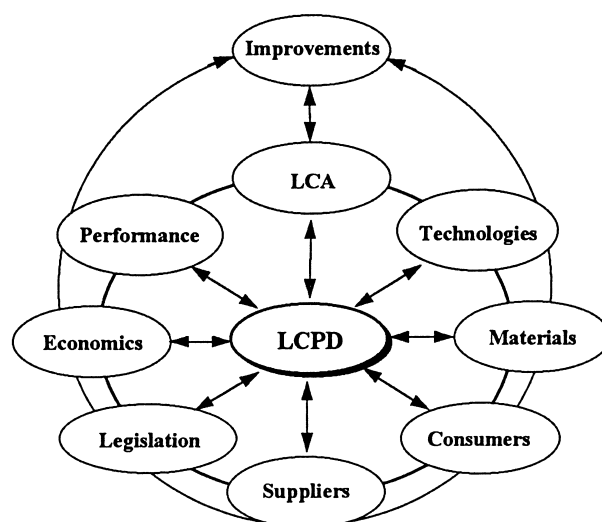

Fig. 17. General methodological framework for Life Cycle Process Design (from Azapagic [139]).

³Kuhn-Tucker multipliers indicate how much of one objective function has to be given up in order to improve the value of the other; for more detail see e.g. [128].

[140], it is also desirable to include the supply chain within the design framework. This enables identification of best suppliers, in terms of their product quality, environmental, health, safety and other performance criteria. For instance, one of the guiding principles in choosing the supplier could be their compliance with ISO 9000 or 14000 or perhaps an international environmental label of their product. Moreover, the design process must include compliance with relevant legislation, such as health and safety regulations and environmental emissions limits. Finally, customer and consumer requirements in terms of the specifications and performance of the product can also be addressed during process design. Once all of the criteria of interest have been identified, a multi-objective optimisation model of the general form Eqs. (1)–(4) can be defined. The system is then optimised on a number of objectives, defined by environmental burdens or impacts and socio-economic functions, subject to the constraints on material and energy balances, productive capacities, technical, legislative and other requirements. As a result, a plethora of non-inferior solutions is obtained, enabling a quantitative evaluation of options for environmental, technical, economic and other improvements of the process system. This whole procedure is dynamic with a continuous exchange of information within and outside the design team to explore systematically the possibilities for improvements.

Therefore, LCPD offers a potential for technological innovation in the process concept and structure through the selection of the best technologies and raw materials over the whole cycle. As already discussed, this can be of particular importance if placed within the context of EMAS and ISO 14000 EMS, as well as the IPPC Directive, which require companies to have a full knowledge of the environmental consequences of their actions, both on- and off-site. Furthermore, as the ‘polluter pays’ and ‘producer responsibility’ initiatives are starting to force manufacturers to reduce waste at source and manage the waste associated with their processes, LCPD can provide a powerful framework for the design of cleaner processes which are environmentally benign and economically profitable.

Similar approaches have been proposed by Kniel et al. [100], Pistikopoulos et al. [102], Stewart and Petrie [104], and others [103,105]. Pistikopoulos et al. [102,103,105], for instance, use a so-called Minimum Environmental Impact (MEI) methodology which embeds LCA principles within a formal process optimisation framework. This approach extends the existing waste minimisation design techniques by providing a more complete description of the environmental impacts of the process. The authors [102,103,105] use an example of the design of a vinyl chloride monomer (VCM) plant to show that the ‘zero emission’ target may not always be the best environmental policy and that an optimal degree of abatement may be preferable instead. This is illustrated in Fig. 18 which reveals that there is a minimum mass of dichloroethane (DCE) discharged beyond which the global environmental impact increases due to the trade-offs

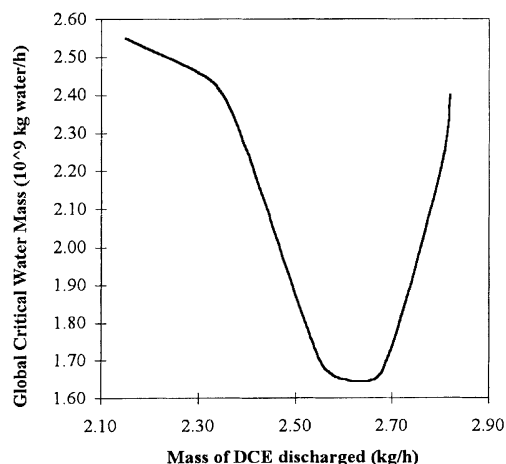

Fig. 18. Effect of the degree of abatement on water discharges from the VCM plant (from Pistikopoulos et al. [102]).

in waste generation over the whole life cycle between system inputs and outputs [102]. This example indicates that from an environmental point of view, minimisation of the output emissions only, as normally carried out in conventional system optimisation, can in fact lead to sub-optimal solutions. Furthermore, it also emphasizes the importance of multi-objective optimisation in which all functions have to be considered simultaneously if global environmental improvements are to be achieved. Targeting for minimum ‘global’ impacts may also result in less expensive plant operation, as was the case in this study.

5. Conclusions

There is a growing need to move away from narrow definitions and concepts in environmental system management. Life Cycle Assessment offers a systematic way to incorporate the entire material and energy supply chain into strategic planning and policy development. This is demonstrated by an increasing number of applications of LCA, both by industry and governments. Some of the newly emerging applications of LCA reviewed in this paper are in process selection, design and optimisation.

The application of LCA to process selection shows that the Best Practicable Option (BPEO) that benefits the environment as a whole must be identified and chosen in the LCA context. The case studies confirm that the choice of BPEO is dependent on the boundaries, operating state of the system and on the background economic system in which it operates. Some of the examples indicate that recycling and recovery of pollutants may not always be the best option environmentally and that the BPEO has to be determined on a case-by-case basis.

LCA can also be coupled with multi-objective optimisation techniques to provide a powerful tool for process design and optimisation. A newly emerging Life Cycle Process Design (LCPD) tool offers a potential for technological

innovation in process concept and structure through selection of best material and process alternatives over the whole life cycle. This approach provides a robust framework for process design by simultaneously optimising on environmental, technical, economic and other criteria. Multi-objective optimisation in this context serves to identify a number of Pareto-optimum options for improved design and operation throughout the whole life cycle. This approach provides a potentially powerful decision making tool which may help process industries identify sustainable options for the future.

Acknowledgements

I wish to express my thanks to Prof. Roland Clift for introducing me to LCA some years ago and for his invaluable contributions to some of the works quoted here. I am also grateful for his and Prof. John Smith's suggestions for improvements to this paper.

References

- [1] ISO 14001, Environmental Management Systems — Specification with Guidance for Use, HMSO, London, 1996.
- [2] Council Regulation (EEC) No. 1836/93 of 29 June 1993 Allowing Voluntary Participation by companies in the Industrial Sector in a Community Eco-Management and Audit Scheme 1993. Official Journal of the European Communities, No. L 168, 10 July, HMSO, 1993, London, pp. 1–18.
- [3] Council Directive 91/61/EC 1996. Concerning Integrated Pollution Prevention and Control, Official Journal of the European Communities, No. L 257, 10 October, HMSO, London, 1996.
- [4] Department of the Environment, Transport and the Regions, U.K. Implementation of EC Directive 96/61 on Integrated Pollution Prevention and Control, Second Consultation Paper, DETR, London, 1998.
- [5] R. Clift, A.J. Longley, Introduction to clean technology, in: R.C. Kirkwood, A.J. Longley (Eds.), *Clean Technology and the Environment*, Chap. 6, Blackie Academic and Professional, Glasgow, 1994.
- [6] R. Clift, Clean technology — The idea and practice, *J. Chem. Tech. Biotech.* 68 (1997) 347–350.
- [7] G. Allen, R. Clift, J.F. Davidson (Eds.), *Clean Technology: The Idea and the Practice*. Philosophical Transactions: Mathematical, Physical and Engineering, 355, Royal Society, 1997, p. 1728.
- [8] R. Clift, Engineering for the environment: The new model engineer and her role, *Process Safety and Environ. Protection* 76(B2) (1998) 151–160.
- [9] I. Boustead, *The Milk Bottle*, Open University Press, Milton Keynes, 1972.
- [10] B. Hannon, *System Energy and Recycling: A Study of the Beverage Industry*, Center for Advanced Computation, University of Illinois, Urbana, IL, 1972.
- [11] G. Sundstrom, Investigation of the energy requirements from raw materials to garbage treatment for 4 Swedish Beer Packaging Alternatives, Report for Rigello Park AB, Sweden, 1973.
- [12] R.G. Hunt, W.E. Franklin, Resources and Environmental Profile Analysis of 9 Beverage container Alternatives. Contract (68-01-1848), U.S. EPA, Washington, DC, 1974.
- [13] E. Barber, K. Fanganas, F. Iannazzi, R. Shamel, K. Halloack, H. Frost, *Selected Characteristics of Disposable and Reusable Napkins*, (PB-275 222/8), Arthur D. Little, Cambridge MA, 1977.
- [14] R.U. Ayres, *Process classification for the industrial material sector*, Technical Report, United Nations Statistical Office, New York, 1978.
- [15] M.P. Lundolm, G. Sundstrom, *Resource and Environmental Impact of Tetra Brik Carton and Refillable and Non-Refillable Glass Bottles*, AB Tetra Pak, Malmo, 1985.
- [16] I. Boustead, *Environmental Impact of the Major Beverage Packaging Systems — U.K. Data 1986 in Response to the EEC Directive 85/339*, INCPEN, London, 1989, pp. 1–4.
- [17] ISO/DIS 14040, *Environmental Management – Life Cycle Assessment – Part 1: Principles and Framework*, 1997.
- [18] J. Fava, R. Dennison, B. Jones, M.A. Curran, B. Vigon, S. Selke, J. Barnum (Eds.), *A Technical Framework for Life-Cycle Assessment*, SETAC and SETAC Foundation for Environmental Education, Washington, DC, 1991.
- [19] F. Consoli, D. Allen, I. Boustead, J. Fava, W. Franklin, A.A. Jensen, N. de Oude, R. Parrish, R. Perriman, D. Postlethwaite, B. Quay, J. Séguin, B. Vigon (eds.), *Guidelines for Life-Cycle Assessment: A 'Code of Practice'*, SETAC, Brussels, 1993.
- [20] A. Azapagic, *Environmental system analysis: The application of linear programming to Life Cycle Assessment*, Ph.D dissertation, University of Surrey, 1996.
- [21] ISO/TC 207/SC 5/WG 2 N 112, ISO/DIS 14041: *Environmental Management – Life Cycle Assessment – Part 2: Goal and Scope Definition and Life Cycle Inventory Analysis*, Voting draft, 1997.
- [22] ISO/TC 207/SC 5/ N 112, ISO/DIS 14042.3: *Environmental Management – Life Cycle Assessment – Part 3: Life Cycle Impact Assessment*, Committee draft, 1998.
- [23] ISO/TC 207/SC 5/ N 112, ISO/DIS 14043: *Environmental Management – Life Cycle Assessment – Part 4: Life Cycle Interpretation*, Voting draft, 1998.
- [24] A. Azapagic, R. Clift, Allocation of environmental burdens by whole-system modelling – The use of linear programming. In: G. Huppes, F. Schneider, (Eds.), *Allocation in LCA*, SETAC, Brussels, 1994, pp. 54–60.
- [25] R. Clift, R. Frischknecht, G. Huppes, A.-M. Tillman, B. Weidema, (Eds.), *Toward a coherent approach to Life Cycle Inventory Analysis*, Report of the Working Group on Inventory Enhancement, SETAC-Europe, Brussels, 1998.
- [26] H.A. Udo de Haes, J.-F. Bensahel, R. Clift, C.R. Fussler, R. Griesshammer, A.A. Jensen, *Guidelines for the application of Life Cycle Assessment in the EU ecolabelling programme*, European Commission, DG XI-A-2, Brussels, 1994.
- [27] H. Hallay, R. Pfiem, *Öko-Controlling Umweltschutz in mittelständischen Unternehmen*, Campus, Frankfurt, 1992.
- [28] S.H. Kalisvaart, J.A.M. Remmerswaal, *The Met-points Method: A new single figure environmental performance indicator*, in: H.A., Udo de Haes, A.A. Jensen, W. Klöpffer, L.-G. Lindfords, (Eds.), *Integrating Impact Assessment into LCA*, SETAC-Europe, Brussels, 1994.
- [29] O. Jolliet, *Impact Assessment of Human and Eco-toxicity in Life Cycle Assessment*. In: H.A. Udo de Haes, (Ed.), *Towards a Methodology for Life Cycle Impact Assessment*, SETAC-Europe, Brussels, 1996.
- [30] K. Habersatter, *Ökobilanz von Packstoffen Stand 1990; Schriftenreihe Umwelt 132*, Bundesamt für Umwelt, Wald und Landschaft, Bern, 1991.
- [31] M. Goedkoop, *The Eco-indicator 95; vol. 9524 (Manual for Designers) and 9523 (Final report)*, Netherlands Agency of Energy and Environment (NoVEM), Amersfoort, 1995.
- [32] S. Ahbe, A. Braunschweig, R. Müller-Wenk, *Methodik für Ökobilanzen auf der Basis ökologischer Optimierung*. Schriftenreihe Umwelt Nr. 133, Bundesamt für Umwelt, Wald und Landschaft (BUWAL), Oktober, Bern, 1990.

- [33] B. Steen, EPS-Default Valuation of Environmental Impacts from Emission and Use of Resources – Version 1996. Annual Report, AFR Report 111, Swedish Environmental Research Institute IVL, Stockholm, April, 1996.
- [34] B. Wilson, B. Jones, The Phosphate Report: A Life Cycle study to evaluate the environmental impact of phosphate and zeolite A-PCA as alternative builders in U.K. laundry detergent formulations, Landbank Environmental Research and Consulting, January, London, 1994.
- [35] F. Schmidt-Bleek, Wieviel Umwelt braucht der Mensch? MIPS-Das Mass für ökologisches Wirtschaften. Birkhäuser Publikationen, Berlin, 1993.
- [36] R. Heijungs, et al. (Eds.), Environmental Life Cycle Assessment of Products: Background and Guide, MultiCopy, Leiden, 1992.
- [37] J. Fava, F. Consoli, R. Dennison, K. Dickson, T. Mohin, B. Vigon, (Eds.), A Conceptual Framework for Life-Cycle Impact Assessment. SETAC and SETAC Foundation for Environmental Education, Pensacola, 1993.
- [38] K.P. Yoon, L. Ching, Multiple Attribute Decision Making – Introduction, Sage, London, 1995.
- [39] R.L. Keeney, H. Raiffa, Decisions with Multiple Objectives: Preferences and Value Trade-offs, Wiley, New York, 1976, pp. 569.
- [40] D.W. Pearce, K. Turner, Benefits Estimates and Environmental Decision-Making, OECD, Paris, 1992.
- [41] P. Miettinen, R.P. Hämäläinen, How to benefit from decision analysis in environmental life cycle assessment (LCA), *Eur. J. Op. Res.* 102(2) (1997) 279–294.
- [42] J.B. Guinée, R. Heijungs, H.A. Udo de Haes, G. Huppes, Quantitative life cycle assessment of products. 2: Classification, valuation and improvement analysis, *J. Cleaner Production* 1(2) (1993) 81–91.
- [43] K. Saur, Life cycle interpretation – A brand new perspective? *Int. J. LCA* 2(1), (1997), 8–10 .
- [44] K. Tahara, T. Kojima, A. Inaba, Evaluation of CO₂ payback time of power plants by LCA, *Energy Conversion and Management*, 38(SS), (1997), S615–S620.
- [45] S. Kato, N. Nomura, Hydrogen gas-turbine characteristics and hydrogen energy system schemes, *Ener. Conv. Manage.* 38(10–13), (1997), 1319–1326 .
- [46] R. Matsushashi, K. Hikita, H. Ishitani, Model analyses for sustainable energy supply taking resource and environmental constraints into consideration energy conversion and management 37(6–8), (1996), 1253–1258.
- [47] H. Audus, IEA greenhouse gas R&D programme: Full fuel cycle studies, *Ener. Conv. Manage.* 37(6–8), (1996), 837–842, .
- [48] R. Dones, R. Frischknecht, Life-cycle assessment of photovoltaic systems: Results of swiss studies on energy chains, *Progr. in Photovoltaics* 6(2) (1998) 117–125.
- [49] E. Eriksson, M. Blinge, G. Lovgren, Life Cycle Assessment of the road transport sector, *Sci. Total Environ.* 190 (1996) 69–76.
- [50] N.L.C. Steele, D.T. Allen, Life-cycle assessment – An abridged life-cycle assessment of electricvehicle batteries, *Environ. Sci. Technol.* 32(1) (1998) A40–A46.
- [51] R. Bretz, P. Fankhauser, Life-cycle assessment of chemical production processes: A tool for ecological optimization, *CHIMIA* 51(5) (1997) 213–217.
- [52] M. Aresta, I. Tommasi, Carbon dioxide utilisation in the chemical industry, *Ener. Conv. Manage.* 38(SS) (1997) S373–S378.
- [53] E. Ophus, V. Digernes, Life-Cycle Assessment of an alkyd emulsion: Improvement in environmental performance, *Jocca – Surface Coatings International* 79(4) (1996) 156.
- [54] I.D. Dobson, Life Cycle Assessment for painting processes: Putting the VOC issue in perspective, *Progress in Organic Coatings*, 27(1–4) 55–58 (1996) .
- [55] M. Franke, H. Kluppel, K. Kirchert, P. Olschewski, Life-cycle assessment – Life-cycle inventory for detergent manufacturing, *Tenside Surfactants Detergents* 32(6) (1995) 508–514.
- [56] B. Solberg-Johansen, Environmental LCA of the nuclear fuel cycle, Ph.D dissertation, vols. 1 and 2, University of Surrey, 1998.
- [57] N.L. Griffin, A clean technology approach for nuclear fuel reprocessing, *J. Chem. Technol. Biotechnol.* 68(4) (1997) 361–366.
- [58] J.G.S. Robertson, J.R. Wood, B. Ralph, R. Fenn, Analysis of lead/acid battery life cycle factors: Their impact on society and the lead industry, *J. Power Sour.* 67(1–2), 225–236 (1997).
- [59] K. Shibata, Y. Waseda, New model for assessment of metal production and recycling systems, *J. Jpn. Inst. Metals* 61(6) (1997) 494–501.
- [60] M. Finkbeiner, E. Hoffmann, G. Kreisel, The functional unit in the life cycle inventory analysis of degreasing processes in the metal-processing industry, *Environ. Manage.* 21(4) (1997) 635–642.
- [61] S.T. Chubbs, B.A. Steiner, Life cycle assessment in the steel industry, *Environ. Progr.* 17(2) (1998) 922–995.
- [62] N. Yoda, Life Cycle Assessment in polymer industry toward the 21st century, *J. Macromol. Sci. – Pure and Appl. Chem.* A33(12) (1996) 1807–1824.
- [63] J. Seppala, M. Melanen, T. Jouttijarvi, L. Kauppi, N. Leikola, Forest industry and the environment: A life cycle assessment study from finland, *Resour. Conser. Recycling*, 23(1–2), 87–105, (1998).
- [64] B. Backlund, Scandinavian collaboration develops Life Cycle Assessment (LCA) as a tool for the forest industry, (in Swedish), *Svensk Papperstidning–Nordisk Cellulosa* 101(3) (1998) 49–50.
- [65] T.L. Kuusinen, R.H. Barker, D.A. Alexander, Life cycle assessment in woven textiles, *Tappi J.* 81(3) (1998) 179–182.
- [66] A.G. Puntener, Risk assessment of leather dyestuffs, *J. Soc. Leather Technol. Chem.* 82(1) (1998) 1–4.
- [67] P.J. Roeleveld, A. Klapwijk, P.G. Eggels, W.H. Rulkens, W. van Starckenburg, Sustainability of municipal wastewater treatment, *Wat. Sci. Technol.* 35(10) (1997) 221–228.
- [68] F.J. Dennison, A. Azapagic, R. Clift, J.S. Colbourne, Assessing management options for wastewater treatment works in the context of Life Cycle Assessment, *Wat. Sci. Technol.*, (1998), in press.
- [69] S. Miyamoto, M. Tekawa, Development of life cycle assessment software and application to personal computer assessment, *Nec Res. Dev.* 39(2) (1998) 77–81.
- [70] P. de Langhe, S. Criel, D. Ceuterick, Green design of telecom products: The ADSL high speed modem as a case study. *IEEE Transactions on Components Packaging and Manufacturing Technology Part A.* 21(1), (1998), 154–167.
- [71] H. Baumann, LCA use in swedish industry, *Int. J. LCA.* 1(3) (1996) 122–126.
- [72] F. Berkhout, Life Cycle Assessment and industrial innovation. Global Environmental Change Programme briefings, No. 14, June, EPSRC, Programme Office, 1997.
- [73] F. Berkhout, R. Howes, The adoption of life-cycle approaches by industry: Patterns and impacts, *Resour. Conser, Recycling* 20(2) (1997) 71–94.
- [74] Environmental Data Services Ltd., ENDS Report 267, April, 1997.
- [75] A.P. Taylor, D. Postlethwaite, Overall Business Impact Assessment (OBIA), 4th LCA Case Studies Symposium, SETAC-Europe, Brussels, 1996, pp. 181–187.
- [76] M.D. Wright, D. Allen, R. Clift, H. Sas, Measuring corporate environmental performance: The ICI environmental burden system, *J. Industrial Ecol.* 1(4) (1997) 117–127.
- [77] R. Clift, Relationship between environmental impacts and added value along the supply chain, 2nd Int. Conf. Technology Policy and Innovation, 3–5 August 1998, Lisbon.
- [78] Official Journal of the European Communities No. L 365/10, 1994.
- [79] HMSO, Producer Responsibility Obligations (packaging waste) Regulations, HMSO, London, 1997.
- [80] I. Boustead, Eco-balance Methodology for Commodity Thermoplastics, PWMI, Brussels, 1992.
- [81] Official Journal of the European Communities No. L 99/1, 1992.
- [82] H.A. Udo de Haes, R. Clift, L. Griesshammer, A.A. Jensen, Practical Guidelines for life Cycle Assessment for the EU Ecolabelling Programme, Final report of third phase, 1996..

- [83] R. Clift, Life Cycle Assessment and Ecolabelling, *J. Cleaner Prod.* 1(3–4), 155–159, 1993.
- [84] OECD, Life Cycle Summaries of OECD Countries, January, 1995.
- [85] M.A. Curran, life-cycle based government policies, *Int. J. LCA* 2(1) (1997) 39–43.
- [86] J.J. Lee, P. O’Callaghan, D. Allen, Critical review of life cycle analysis and assessment techniques and their application to commercial activities, *Resour., Conser. Recycling* 13 (1995) 37–56.
- [87] B.P. Weidema, I. Krüger (Eds.), *Environmental Assessment of Products: A Textbook on Life Cycle Assessment*, 2nd edn., UETP-EEE, Finnish Association of Graduate Engineers, Helsinki, 1993.
- [88] B. Pedersen, K. Christiansen, A meta-review on product Life Cycle Assessment, in: *Product Life Cycle Assessment – Principles and Methodology*. Series: Nordic Council of Ministers, Copenhagen, Nord, p. 9, 1992.
- [89] B. Pedersen (Ed.), *Environmental Assessment of Products. A Course on Product Life Cycle Assessment*, UETP-EEE, Helsinki, 1993.
- [90] A-M. Tillman, H. Baumann, E. Eriksson, T. Rydberg, . *Life-Cycle Analysis of Packaging Materials*. Calculation of Environmental Load, Chalmers Industri Teknik, Gothenburg, 1991.
- [91] B.W. Vigon, D.A. Tolle, B.W. Cornaby, H.C. Latham, C.L. Harrison, T.L. Boguski, R.G. Hunt, J.D. Sellers (Eds.), *Life Cycle Assessment: Inventory Guidelines and Principles*, U.S. EPA, Washington DC, 1993.
- [92] A. Azapagic, Life Cycle Assessment: A tool for innovation and improved environmental performance, 1st Int. Conf. Technology Policy and Innovation, 2–4 July, Macau, 1997.
- [93] G. Fleischer, W.-P. Schmidt, Iterative screening LCA in an ecodesign tool, *Int. J. LCA* 2(1) (1997) 20–24.
- [94] RMIT A Guide to EcoReDesign, Royal Melbourne Institute of Technology, Melbourne, Australia, 1996.
- [95] G.A. Kekoleian, The application of Life Cycle Assessment to design, *Cleaner Prod.* 1(3–4), (1993), 143–150.
- [96] K.A. Golonka, D.J. Brennan, Application of Life Cycle Assessment to process selection for pollutant treatment: A case study of sulphur dioxide emissions from Australian metallurgical smelters, *Trans. IChemE*, vol. 74, Part B, May, (1996), pp. 105–119.
- [97] G. Rice, The Application of Life Cycle Assessment to industrial process selection, *EngD Portfolio*, University of Surrey, 1997.
- [98] E. Vyzi, A. Azapagic, Life Cycle Assessment as a tool for identifying the Best Practicable Environmental Option (BPEO), Research report, University of Surrey, 1998.
- [99] A. Yates, LCA: Clean-up technologies and abatement of gaseous pollutant emissions from chemical processing plant, *EngD Portfolio*, University of Surrey, 1998.
- [100] G.E. Kniel, K. Delmarco, J.G. Petrie, Life Cycle Assessment applied to process design: Environmental and economic analysis and optimisation of a nitric acid plant, *Environ. Progr.* 15(4) (1996) 221–228.
- [101] C. Pessoa, Life cycle methods and applications: Issues and perspectives, *J. Cleaner Prod.* 1, 3–4, (1993), 139–142.
- [102] E.N. Pistikopoulos, S.K. Stefanis, A.G. Livingston, A methodology for minimum environmental impact analysis, in: M.M. El-Halwagi, (Ed.), *Pollution Prevention via Process and Product Modification*, AIChE Symposium Series, 90(303), AIChE, New York, 1996.
- [103] S.K. Stefanis, A.G. Livingston, E.N. Pistikopoulos, A framework for minimizing environmental impact of industrial processes. *Proc. The 1995 IChemE Research Event*, vol. 1, IChemE, Rugby, pp. 164–166, 1995.
- [104] M. Stewart, J.G. Petrie, Life Cycle Assessment for process design – The case of minerals processing, in: M.A. Sánchez, F. Vergara, S.H. Castro (Eds.), *Clean Technology for the Mining Industry*, University of Concepción, Chile, pp. 67–81.
- [105] S.K. Stefanis, A.G. Livingston, E.N. Pistikopoulos, . A framework for minimizing environmental impact of industrial processes. *Proc. The 1995 IChemE Research Event*, vol. 1, IChemE, Rugby, pp. 164–166, 1995.
- [106] A. Azapagic, R. Clift, 1995a. Whole system modelling and Life Cycle Assessment, *Proc. The 1995 IChemE Research Event*, vol. 1, IChemE, Rugby, pp. 429–431.
- [107] A. Azapagic, R. Clift, Life Cycle Assessment and linear programming – Environmental optimisation of product system, *Comp. & Chem. Eng.* 19 (suppl), (1995b), 229–234.
- [108] A. Azapagic, R. Clift, S.C. Cowell, J. Lamb, Environmental management of product system – Application of Multi- objective linear programming to Life Cycle Assessment, *Proc. The 1996 IChemE Research Event*, vol. 2, IChemE, Rugby, 1996.
- [109] A. Azapagic, R. Clift, J. Lamb, Application of Multi-objective linear programming to environmental process optimisation, *AIChE 1996 Spring National Meeting*, 25–29 February, New Orleans, 1996, LA.
- [110] A. Azapagic, R. Clift, Linear programming as a tool in Life Cycle Assessment, *Int. J. LCA* 3(6) (1998) 305–316.
- [111] A. Azapagic, R. Clift, Applying Life Cycle thinking to process design and operation for the environment, 8th National Meeting of SAICChE, 16–18 April, Cape Town, South Africa, 1997.
- [112] The Environment Agency, *Best Practicable Environmental Option Assessment for Integrated Pollution Control*, vol. I: Principles and Methodology, HMSO, London, 1997.
- [113] Environmental Data Services, ENDS, Report 269, June, 1997, pp. 36–37.
- [114] M.A. Meier, Eco-efficiency evaluation of waste gas purification systems in the chemical industry, in: W. Klöpffer, (Ed.), *LCA Documents*, vol. 2, Ecomed Publishers, Germany, 1997.
- [115] N. de Nevers, *Air Pollution Control Engineering*, McGraw-Hill, London, 1995.
- [116] T.E. Graedel, B.R. Allenby, *Industrial Ecology*, Prentice Hall, Englewood Cliffs, NJ, 1995.
- [117] M.M. El-Halwagi, V. Manousiouthakis, Automatic synthesis of mass-exchange networks with single-component targets, *Chem. Eng. Sci.* 45(9) (1990) 2813.
- [118] Y.P. Wang, R. Smith, Waste water minimisation, *Chem. Eng. Sci.* 49(7) (1994) 98.
- [119] A.R. Ciric, S.G. Huchette, Economic sensitivity analysis of waste treatment costs in source reduction projects: Discrete optimisation problems, *Ind. Eng. Chem. Res.* 32 (1993) 2636.
- [120] A.R. Ciric, T. Jia, Economic sensitivity analysis of waste treatment costs in source reduction projects: Continuous optimisation problems, *Comput. Chem. Eng.* 18(6) (1994) 481–495.
- [121] A.A. Linninger, C. Han, S.A. Ali, E. Stephanopoulos, G. Stephanopoulos, Concept of ZAP (zero avoidable pollution) in the synthesis and evaluation of batch pharmaceutical processes. Paper presented at the 1994 Annual AIChE Meeting, San Francisco, CA, 1994.
- [122] A.A. Linninger, E. Stephanopoulos, S.A. Ali, C. Han, G. Stephanopoulos, Generation and assessment of batch processes with ecological considerations, *ESCAPE-5 Conf.*, 11–14 June, Bled, Slovenia, 1995.
- [123] C.A. Wentz, Waste minimisation and resource recovery. In: *Hazardous Waste Management*, McGraw-Hill, New York, 1989.
- [124] G.B. Dantzig, *Linear Programming and Extensions*, Princeton University Press, Princeton, NJ, 1963.
- [125] C.A. Floudas, *Nonlinear and Mixed-integer Optimization: Fundamentals and Applications*, Oxford University Press, Oxford, 1995.
- [126] GAMS Software GmbH, Giessen, Germany, 1998.
- [127] T.F. Edgar, D.M. Himmelblau, *Optimization of Chemical Processes*, McGraw-Hill, New York, 1988.
- [128] J.L. Cohon, Multiobjective programming and planning. In: *Mathematics in Science and Engineering*, Academic Press, New York, 1978.
- [129] C.L. Hwang, S.R. Paidy, K. Yoon, Mathematical programming with multiple objectives: A tutorial, *Comput. Op. Res.* 7 (1980) 5–31.
- [130] D.W. Pearce, *Cost-benefit Analysis*, 2nd edn., Macmillan, London, 1983.

- [131] D.W. Pearce, A. Markandya, E. Barbier, *Blueprint for a Green Economy*, Earthscan, London, 1989.
- [132] D.W. Pearce, K. Turner, *Benefits Estimates and Environmental Decision-making*, OECD, Paris, 1992.
- [133] R.K. Turner, D.W. Pearce, I. Bateman, *Environmental Economics – An Elementary introduction*, Harvester Wheatsheaf, New York, 1994, 328 pp.
- [134] R.L. Keeney, H. Raiffa, *Decisions with Multiple Objectives: Preferences and Value Trade-offs*, Wiley, New York, 1976.
- [135] K.P. Yoon, L. Ching, *Multiple Attribute Decision Making: Introduction*, Sage, London, 1995.
- [136] A. Azapagic, R. Clift, Life Cycle Assessment and Multi-objective optimisation, *J. Cleaner Prod.* 7(2) (1998) 135–143.
- [137] A. Azapagic, R. Clift, The application of Life Cycle Assessment to process optimisation. *Comp. and Chem. Eng.*, (1998), in press.
- [138] L. Alting, M. Hauschild, H. Wenzel, Environmental assessment in product development, in: *Clean Technology: The Idea and the Practice*. *Philosophical Transactions: Mathematical, Physical and Engineering*, 355(1728), Royal Society, London, 1997, pp. 1373–1388.
- [139] A. Azapagic, Design for optimum use of resources - cascaded use of materials. *Proc. 2nd Int. Conf. Technology Policy and Innovation*, 3–5 August, Lisbon, 1998.
- [140] Chemical Industries Associations, *The UK Indicators of Performance 1990–97*, CIA, London, 1998.